

mimatic®

Tool Systems

Winkelköpfe

Angle Heads

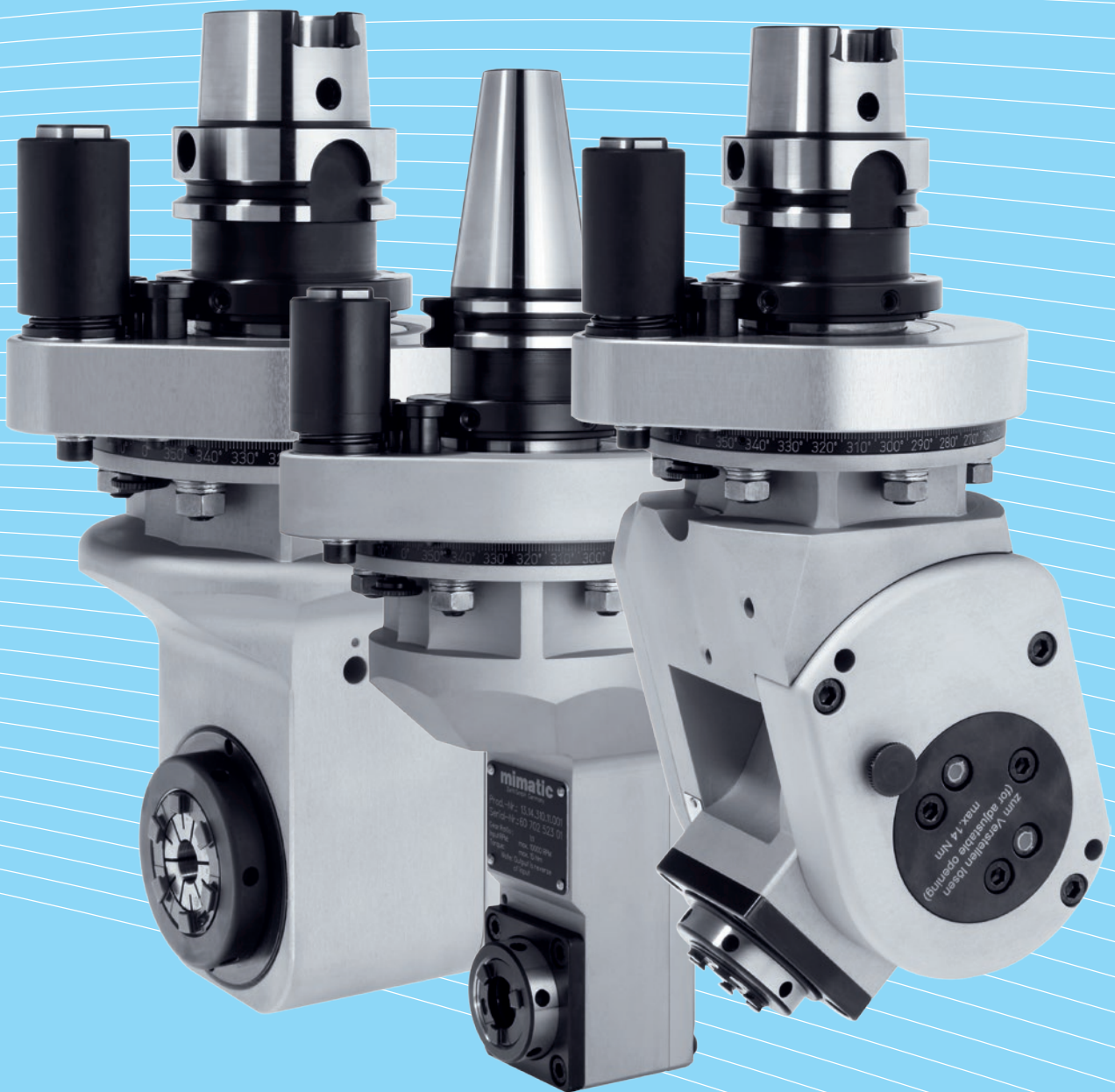

Werkzeugsysteme für höchste Ansprüche

Tool Systems for Highest Demands

Seit 1974 entwickeln und produzieren wir Zerspanungswerkzeuge und angetriebene Werkzeuge für CNC Werkzeugmaschinen. Unsere Produkte kommen in den unterschiedlichsten Anwendungsbereichen für die spanabhebende Fertigung bei Kunden der Automobilindustrie, Automobilzulieferer, Elektrotechnik, Fahrzeugbau, Gießereien, Maschinenbau und Medizintechnik zum Einsatz.

Since 1974, we have been developing and producing cutting tools and driven tools for CNC machine tools. Our products are used in various fields of application for the machining industry for customers of the automotive industry, automotive suppliers, electrical engineering, vehicle construction, foundries, mechanical engineering and medical technology.



Die Region Allgäu gilt weit über ihre Grenzen hinaus als Inbegriff für Lebensqualität, intakte Natur und idyllische Landschaften. Sie ist aber ebenso bekannt für ihre enorme wirtschaftliche Leistungsfähigkeit und Innovationskraft im Werkzeug- und Maschinenbau. Unser Standort im Allgäu unterhält eine leistungsfähige Produktion mit allen Einrichtungen eines modernen Industrieunternehmens.

The Allgäu region of Bavaria reputation reaches beyond its borders, because of its natural beauty, undisturbed nature and idyllic landscapes. It is also well known for its industrial power and innovative thinking in toolmaking and mechanical engineering. Our location in the Allgäu has a powerful production with all facilities of a modern industrial enterprise.



Standorte Locations

Zentrale Headquarter

mimatic GmbH

Westendstraße 3
87488 Betzigau
Germany
Tel. +49 831-57444 - 0
Fax +49 831-57444 - 90
info@mimatic.de
www.mimatic.de

Forschung & Entwicklung / *Research & Development*
Produktion / *Production*
Vertrieb / *Sales*
Service / *Service*



Niederlassungen Subsidiaries

Zettl mimatic Inc.

25713 N Hillview Ct.
Building 4
Mundelein IL 60060
USA
Tel.: +1 847 734 9222 Ext. 1001

Vertrieb / *Sales*
Service / *Service*

mimatic Tool Systems (Shanghai) Co.Ltd.

Jinhui Road No.1688,
Minhang District
CN-201807 Shanghai
China
Tel.: +86 21 62213668

Vertrieb / *Sales*
Service / *Service*



Zertifikate Certificates



DIN EN ISO 9001:2015



AEO F

Zugelassener Wirtschaftsbeteiligter
Authorized Economic Operator

Produkte Products

**Zerspanungswerkzeuge
Cutting Tools**



**Angetriebene Werkzeuge
für Drehmaschinen
Cutting Tools for Turning
Machines**



**Winkelköpfe
für Fräsmaschinen
Angle Heads for
Milling Machines**

Mehrspindleinheiten
Multi Spindle Units



Spanntechnik
Clamping Technology



Sonderlösungen
Special Solutions



Innovationen für Industrie 4.0 (IIoT) Innovations for Industry 4.0 (IIoT)

Free Your Tool Monitoring with **eltimon**®



Das revolutionäre System **eltimon** (electronic live tool integrated monitoring) zur Digitalisierung von Angetriebenen Werkzeugen und Winkelköpfen

- Visualisierung über **eltimon**-App auf Ihr Handy
- Datenspeicherung im **eltimon**-core im Live Tool
- Synchronisation über **eltimon**-cloud
- Echtzeit-Analysen, Trends und Zustände
- Entscheidungshilfen, Erinnerungen, Transparenz
- Maximale Lebensdauer für Ihre Live Tools

The Revolutionary System **eltimon** (electronic live tool integrated monitoring) for Digitization of Live Tools and Angle Heads

- Visualization using **eltimon**-app on your mobile phone
- Data storage in the **eltimon**-core in the live tool
- Synchronization through **eltimon**-cloud
- Real time analyses, trends and status
- Augmented operator, decision-support, reminders
- Maximum lifetime for your live tools

DrehTrennFräsen Turn Cut Milling

mimaticDTF

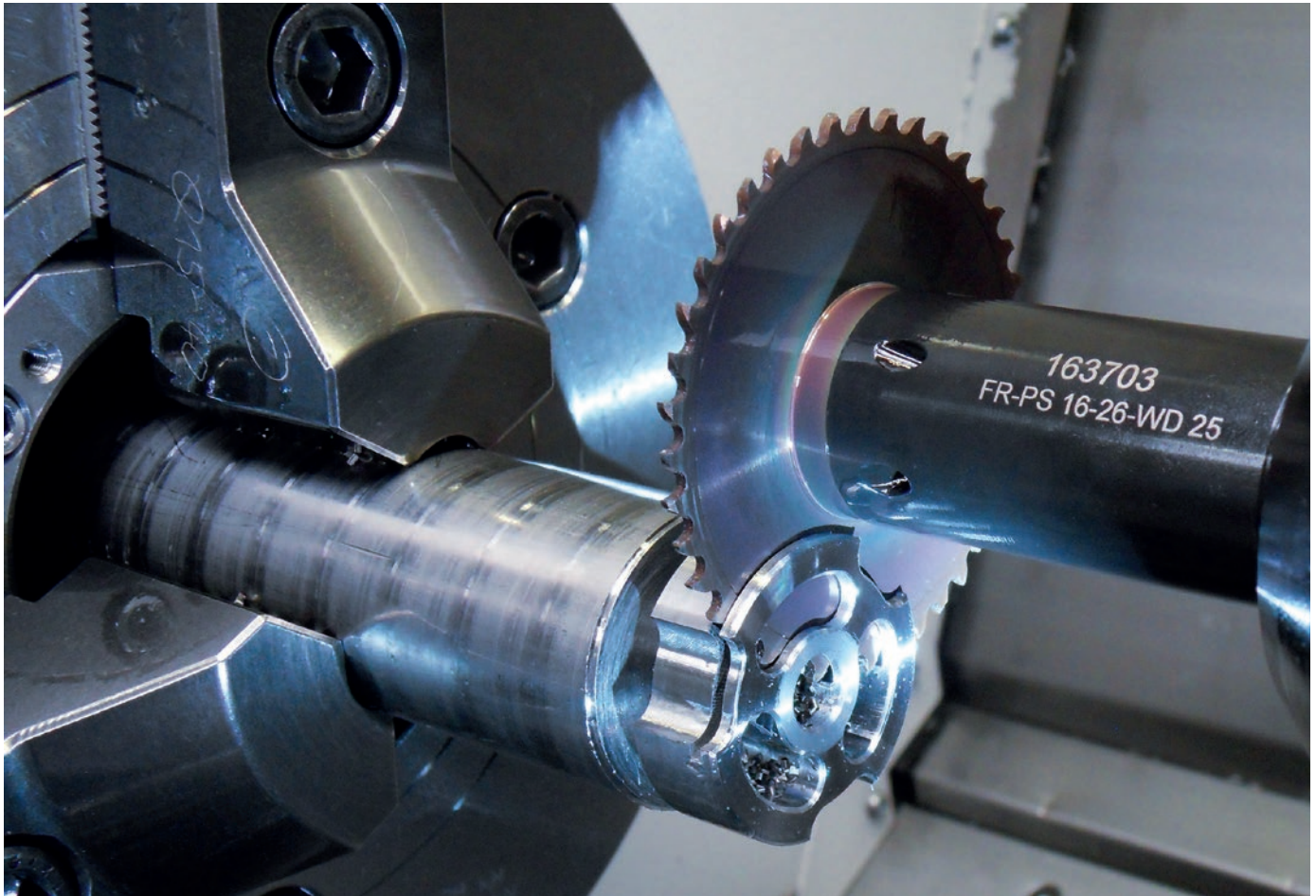

- | | |
|--------------------------|-----------------------------------|
| • Kurze Prozesszeiten | • <i>Short processing times</i> |
| • Hohe Prozesssicherheit | • <i>High process reliability</i> |
| • Materialeinsparung | • <i>Material saving</i> |
| • Hohe Oberflächengüte | • <i>High surface quality</i> |
| • Gratfreiheit | • <i>Absence of burrs</i> |
| • Kurze Späne | • <i>Short chips</i> |

**Schneller Trennen als jeder Andere!
DrehTrennFräsen statt Stechen.**

**Faster Parting Off Than Anybody Else!
Turn Cut Milling Instead of Parting Off.**



Service und Wartung von AGW's und Winkelköpfen aller Fabrikate

Service and Maintenance of Live Tools and Angle Heads of All Brands

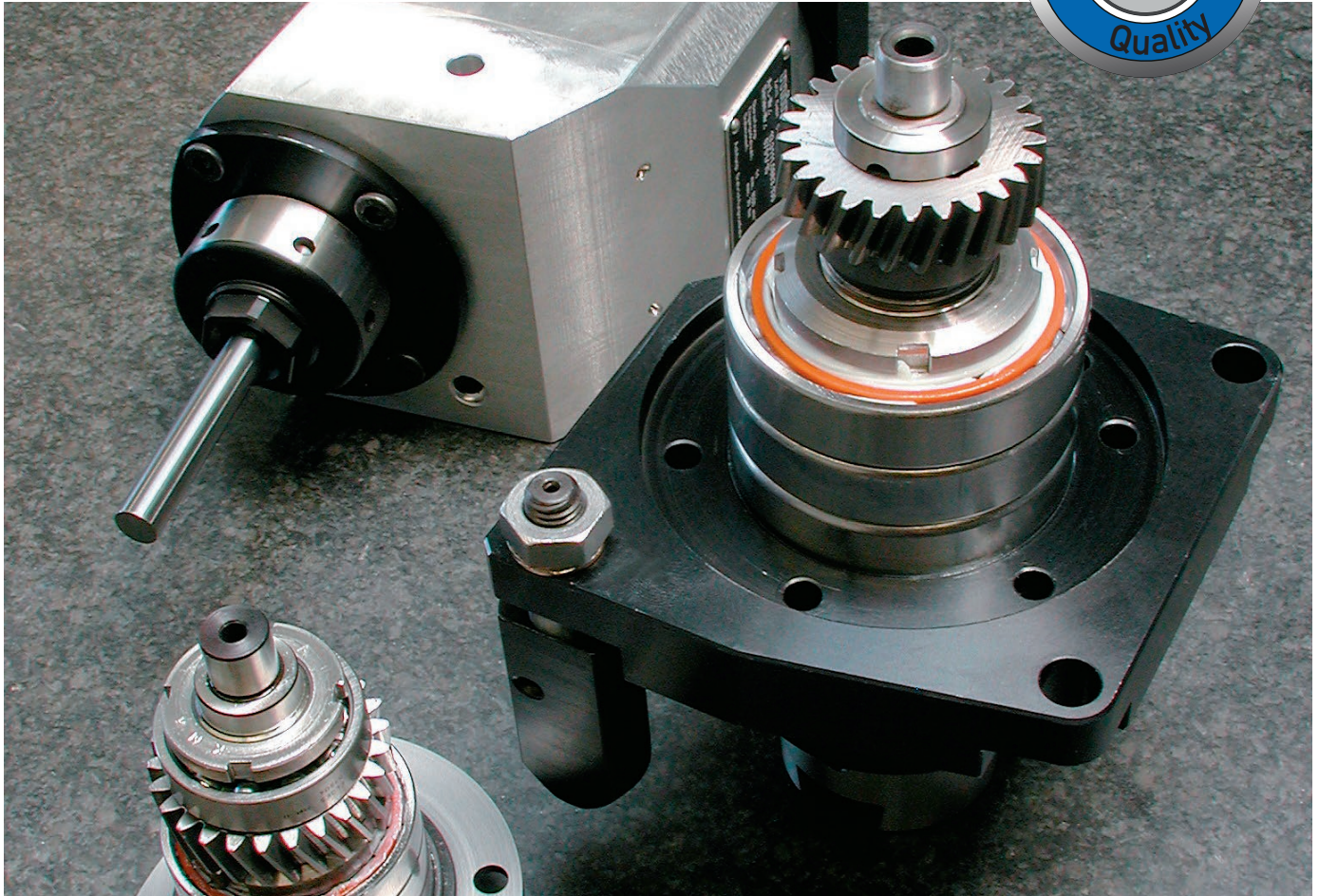

Präventive Wartung und Reparaturen von Angetriebenen Werkzeugen und Winkelköpfen sind wichtige Faktoren, um

- 1) Werkzeugkosten zu begrenzen**
- 2) Werkzeugverfügbarkeit sicherzustellen**
- 3) Prozesssicherheit zu gewährleisten**
- 4) Lebensdauer zu erhöhen**

Verwendet werden nur hochwertige Lager und Spindellager von Deutschen Markenherstellern. Zusammen mit leistungsstarken Dichtungen kann die einwandfreie Funktion des AGW wieder gewährleistet werden. Dafür erhalten Sie die **mimatic-Garantie** mit **Gütesiegel**.

Preventive maintenance and repair of driven tools and angle heads are important factors to

- 1) Limit the tool cost**
- 2) Ensure the tool availability**
- 3) Ensure the continuing reliability**
- 4) Increase the lifetime**

Only high-quality bearings and spindle bearings from German brand manufacturers are used. Together with high-quality friction-optimised seals, the proper functioning of your driven toolholder is ensured again. For this you will get the **mimatic warranty seal**.

Ablauf

1. Das AGW wird an mimatic gesendet.
2. Sie erhalten ein Wartungs-/Reparaturangebot mit Info zur Art des Schadens, Verschleißbild und event. mögliche Verschleißursache (max. 8 Arbeitstage).
3. Sie erteilen den Reparaturauftrag oder verfügen die sonstige Verwendung der demontierten Teile (10 Arbeitstage Ihrerseits).

Alle gewarteten oder reparierten Angetriebenen Werkzeuge, Winkelköpfe oder auch Fremdfabrikate werden einem Funktionsdauerstest auf dem mimatic Prüfstand unterzogen.

Procedure

1. The driven toolholder is sent to mimatic.
2. You will receive a maintenance / repair offer info to the nature of the damage, the wear image and if possible, causes of wear (8 working days max).
3. You grant the repair order or determine the other use of the demounted parts (10 working days on your part).

All serviced or repaired driven toolholders are subjected to a long-time function test on the mimatic test bench.

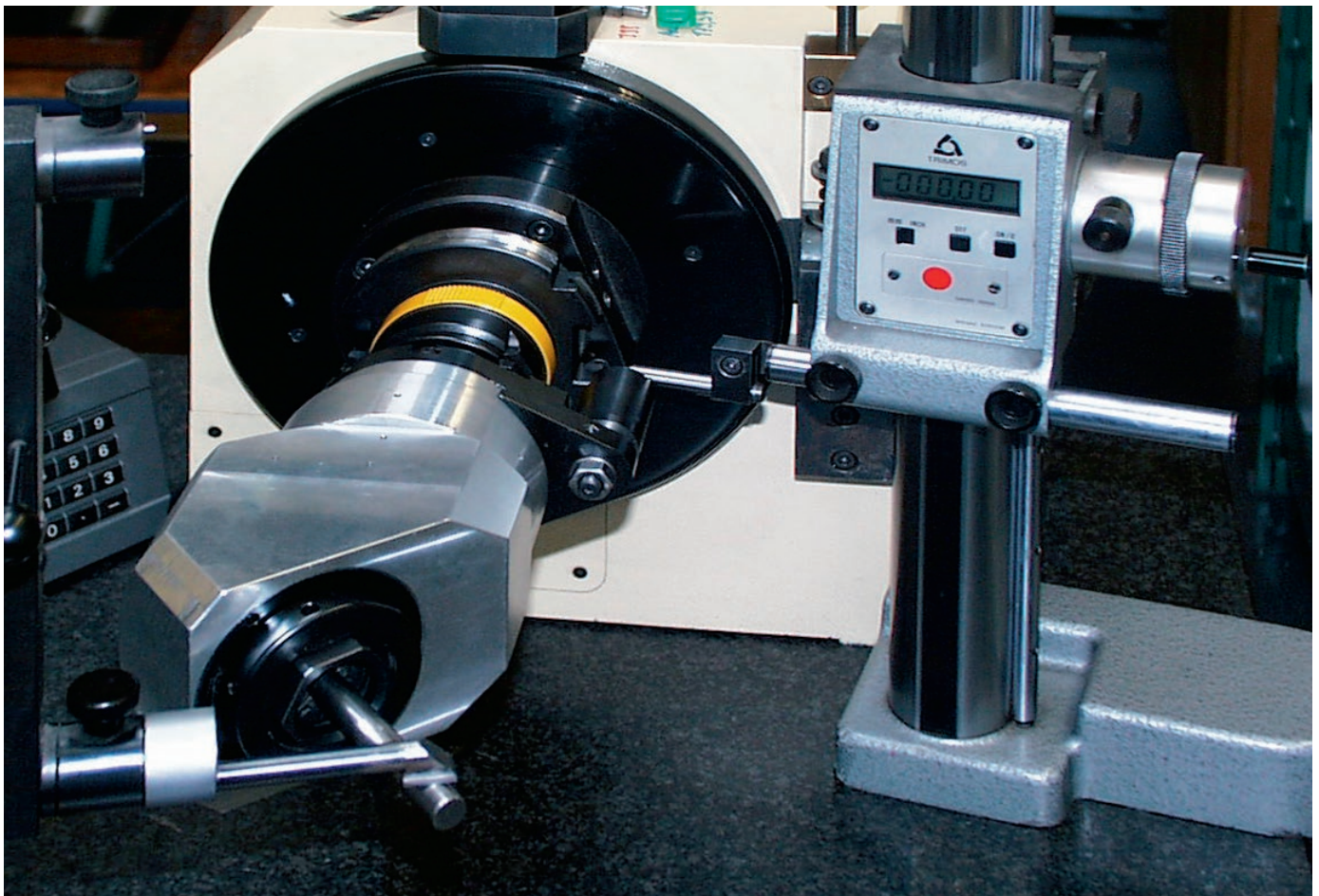

Inhalt Content

DIN 69871

**Auswahl nach
Eintauchdurchmesser E
und Eintauchtiefe L₁**

*Selection by
Clearance Diameter E
and Milling Depth L₁*

90° Winkelkopf

Angle Head 90°



**90° Doppel-
Winkelkopf**

*Double
Angle Head 90°*



**90° Winkelkopf
zurückversetzt**

*Angle Head 90°
Offset Type*



**90° Winkelkopf
zurückversetzt
schmale Bauform**

*Angle Head 90°
Offset Slim Type*



**Winkelschwenk-
einheit 0-98°**

*Angle Head,
Adjustable 0-98°*



SK 40			SW			DW			ZW			ZWS			WS							
Baugröße Size	Aufnahme Tool holder	Kühlung Coolant	E Ø mm	L ₁ mm	Seite Page	E Ø mm	L ₁ mm	Seite Page	E Ø mm	L ₁ mm	Seite Page	E Ø mm	L ₁ mm	Seite Page	E Ø mm	L ₁ mm	Seite Page					
0	ER 11				22			23			24	50	38	25			26					
1	ER 16	✓	91	80																		
3	ER 20	✓														75		80		-	91	
	mi	✓														100		80		-	91	
5	ER 25		110	80			125		80			103	80			82		76		-	96	
		✓	120	80			125		80			103	80			82		76		-	96	
	mi		138	80			200		80			130	80			125		76		-	96	
		✓	146	80			200		80			130	80			125		76		-	96	
7	ER 32		145	80			152		80			128	100									
		✓	155	80			152		80			128	100									
	mi		172	80			220		80			150	100									
		✓	178	80			220		80			150	100									

SK 50			SW			DW			ZW			ZWS			WS							
Baugröße Size	Aufnahme Tool holder	Kühlung Coolant	E Ø mm	L ₁ mm	Seite Page	E Ø mm	L ₁ mm	Seite Page	E Ø mm	L ₁ mm	Seite Page	E Ø mm	L ₁ mm	Seite Page	E Ø mm	L ₁ mm	Seite Page					
0	ER 11				27			28			29	50	38	30			31					
5	ER 25		110	75			125		70			103	79			82		76		-	96	
		✓	120	75			125		70			103	79			82		76		-	96	
	mi		138	75			200		70			133	79			125		76		-	96	
		✓	146	75			200		70			133	79			125		76		-	96	
7	ER 32		145	75			152		70			128	94			102		100		-	108	
		✓	155	75			152		70			128	94			102		100		-	108	
	mi		172	75			220		70			152	94			135		100		-	108	
		✓	178	75			220		70			152	94			135		100		-	108	
9	ER 40		195	105			210		109			140	152									
		✓	195	105			210		109			140	152									
	mi		224	105			250		109			165	152									
		✓	224	105		250	109		165	152												

Inhalt Content

DIN 69893 A

**Auswahl nach
Eintauchdurchmesser E
und Eintauchtiefe L₁**

**Selection by
Clearance Diameter E
and Milling Depth L₁**

90° Winkelkopf

Angle Head 90°



**90° Doppel-
Winkelkopf**

*Double
Angle Head 90°*



**90° Winkelkopf
zurückversetzt**

*Angle Head 90°
Offset Type*



**90° Winkelkopf
zurückversetzt
schmale Bauform**

*Angle Head 90°
Offset Slim Type*



**Winkelschwenk-
einheit 0-98°**

*Angle Head,
Adjustable 0-98°*



HSK 63			SW			DW			ZW			ZWS			WS		
Baugröße Size	Aufnahme Tool holder	Kühlung Coolant	E Ø mm	L ₁ mm	Seite Page	E Ø mm	L ₁ mm	Seite Page	E Ø mm	L ₁ mm	Seite Page	E Ø mm	L ₁ mm	Seite Page	E Ø mm	L ₁ mm	Seite Page
0	ER 11											50	38				
1	ER 16	✓	91	80													
3	ER 20	✓										75	80		-	91	
	mi	✓										100	80		-	91	
5	ER 25		110	80	32	125	80	33	103	80	34	82	76	35	-	96	36
		✓	120	80		125	80		103	80		82	76		-	96	
		138	80	200		80	130		80	125		76	-		96		
	✓	146	80	200		80	130		80	125		76	-		96		
7	ER 32		145	80		152	80		128	100							
		✓	155	80	152	80	128	100									
	mi		172	80		220	80		150	100							
		✓	178	80		220	80		150	100							

HSK 100			SW			DW			ZW			ZWS			WS		
Baugröße Size	Aufnahme Tool holder	Kühlung Coolant	E Ø mm	L ₁ mm	Seite Page	E Ø mm	L ₁ mm	Seite Page	E Ø mm	L ₁ mm	Seite Page	E Ø mm	L ₁ mm	Seite Page	E Ø mm	L ₁ mm	Seite Page
0	ER 11											50	38				
5	ER 25		110	75		125	70		103	79		82	76		-	96	
		✓	120	75		125	70		103	79		82	76		-	96	
	mi		138	75		200	70		133	79		125	76		-	96	
		✓	146	75		200	70		133	79		125	76		-	96	
7	ER 32		145	75	37	152	70	38	128	94	39	102	100	40	-	109	41
		✓	155	75		152	70		128	94		102	100		-	109	
	mi		172	75		220	70		152	94		135	100		-	109	
		✓	178	75		220	70		152	94		135	100		-	109	
9	ER 40		195	109		210	109		140	152							
		✓	195	109		210	109		140	152							
	mi		224	109		250	109		165	152							
		✓	224	109		250	109		165	152							

Inhalt Content

MAS-BT JIS 6339

**Auswahl nach
Eintauchdurchmesser E
und Eintauchtiefe L₁**

*Selection by
Clearance Diameter E
and Milling Depth L₁*

90° Winkelkopf

Angle Head 90°



**90° Doppel-
Winkelkopf**

*Double
Angle Head 90°*



**90° Winkelkopf
zurückversetzt**

*Angle Head 90°
Offset Type*



**90° Winkelkopf
zurückversetzt
schmale Bauform**

*Angle Head 90°
Offset Slim Type*



**Winkelschwenk-
einheit 0-98°**

*Angle Head,
Adjustable 0-98°*



MAS-BT 40			SW			DW			ZW			ZWS			WS		
Baugröße Size	Aufnahme Tool holder	Kühlung Coolant	E Ø mm	L ₁ mm	Seite Page	E Ø mm	L ₁ mm	Seite Page	E Ø mm	L ₁ mm	Seite Page	E Ø mm	L ₁ mm	Seite Page	E Ø mm	L ₁ mm	Seite Page
0	ER 11											50	38				
1	ER 16	✓	91	80													
3	ER 20	✓										75	80		-	91	
	mi	✓										100	80		-	91	
5	ER 25		110	80	42	125	80	43	103	80	44	82	76	45	-	96	46
		✓	120	80		125	80		103	80		82	76		-	96	
		138	80	200		80	130		80	125		76	-		96		
	✓	146	80	200		80	130		80	125		76	-		96		
7	ER 32		145	80		152	80		128	100							
		✓	155	80	152	80	128	100									
		172	80	220	80	150	100										
	✓	178	80	220	80	150	100										

MAS-BT 50			SW			DW			ZW			ZWS			WS		
Baugröße Size	Aufnahme Tool holder	Kühlung Coolant	E Ø mm	L ₁ mm	Seite Page	E Ø mm	L ₁ mm	Seite Page	E Ø mm	L ₁ mm	Seite Page	E Ø mm	L ₁ mm	Seite Page	E Ø mm	L ₁ mm	Seite Page
0	ER 11											50	38				
5	ER 25		110	75		125	70		103	79		82	76		-	96	
		✓	120	75		125	70		103	79		82	76		-	96	
		138	75		200	70		133	79		125	76		-	96		
	✓	146	75		200	70		133	79		125	76		-	96		
7	ER 32		145	75	47	152	70	48	128	94	49	102	100	50	-	109	51
		✓	155	75		152	70		128	94		102	100		-	109	
		172	75	220		70	152		94	135		100	-		109		
	✓	178	75	220		70	152		94	135		100	-		109		
9	ER 40		195	109		210	109		140	152							
		✓	195	109		210	109		140	152							
		224	109		250	109		165	152								
	✓	224	109		250	109		165	152								

Inhalt Content

ANSI-CAT

**Auswahl nach
Eintauchdurchmesser E
und Eintauchtiefe L₁**

*Selection by
Clearance Diameter E
and Milling Depth L₁*

90° Winkelkopf

Angle Head 90°



**90° Doppel-
Winkelkopf**

*Double
Angle Head 90°*



**90° Winkelkopf
zurückversetzt**

*Angle Head 90°
Offset Type*



**90° Winkelkopf
zurückversetzt
schmale Bauform**

*Angle Head 90°
Offset Slim Type*



**Winkelschwenk-
einheit 0-98°**

*Angle Head,
Adjustable 0-98°*



ANSI-CAT 40			SW			DW			ZW			ZWS			WS		
Baugröße Size	Aufnahme Tool holder	Kühlung Coolant	E Ø mm	L ₁ mm	Seite Page	E Ø mm	L ₁ mm	Seite Page	E Ø mm	L ₁ mm	Seite Page	E Ø mm	L ₁ mm	Seite Page	E Ø mm	L ₁ mm	Seite Page
0	ER 11											50	38				
1	ER 16	✓	91	80													
3	ER 20	✓										75	80		-	91	
	mi	✓										100	80		-	91	
5	ER 25		110	80	52	125	80	53	103	80	54	82	76	55	-	96	56
		✓	120	80		125	80		103	80		82	76		-	96	
		138	80	200		80	130		80	125		76	-		96		
	✓	146	80	200		80	130		80	125		76	-		96		
7	ER 32		145	80		152	80		128	100							
		✓	155	80	152	80	128	100									
		172	80	220	80	150	100										
	✓	178	80	220	80	150	100										

ANSI-CAT 50			SW			DW			ZW			ZWS			WS		
Baugröße Size	Aufnahme Tool holder	Kühlung Coolant	E Ø mm	L ₁ mm	Seite Page	E Ø mm	L ₁ mm	Seite Page	E Ø mm	L ₁ mm	Seite Page	E Ø mm	L ₁ mm	Seite Page	E Ø mm	L ₁ mm	Seite Page
0	ER 11											50	38				
5	ER 25		110	75		125	70		103	79		82	76		-	96	
		✓	120	75		125	70		103	79		82	76		-	96	
		138	75		200	70		133	79		125	76		-	96		
	✓	146	75		200	70		133	79		125	76		-	96		
7	ER 32		145	75	57	152	70	58	128	94	59	102	100	60	-	109	61
		✓	155	75		152	70		128	94		102	100		-	109	
		172	75	220		70	152		94	135		100	-		109		
	✓	178	75	220		70	152		94	135		100	-		109		
9	ER 40		195	100		210	105		140	152							
		✓	195	100		210	105		140	152							
		224	100		250	105		165	152								
	✓	224	100		250	105		165	152								

Inhalt Content

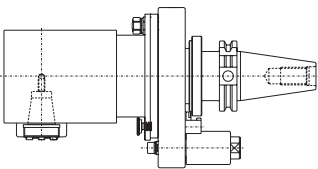
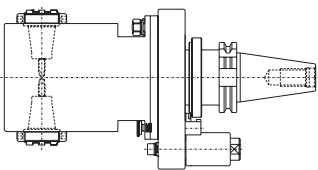
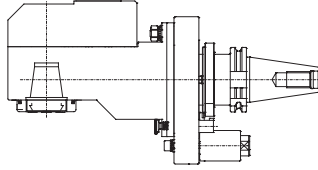
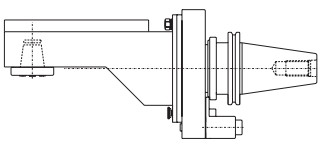
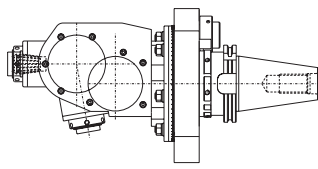
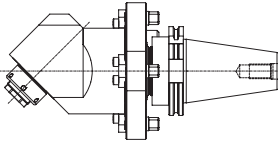
	Typ	DIN	Schaft Shank	Seite Page
<p>90° Winkelkopf Übersetzung $i = 1:1$ Kühlmittelzufuhr: ohne/extern/intern</p> <p>Angle Head 90° Gear Ratio $i = 1:1$ Coolant supply: without/external/internal</p> 	SW	DIN 69871	SK 40	22
		DIN 69893 A	SK 50	27
			HKS 63	32
			HSK 100	37
		MAS-BT JIS 6339	BT 40	42
	BT 50	47		
	ANSI-CAT	CAT 40	52	
		CAT 50	57	
<p>90° Doppel-Winkelkopf Übersetzung $i = 1:1$ Kühlmittelzufuhr: ohne/extern</p> <p>Double Angle Head 90° Gear Ratio $i = 1:1$ Coolant supply: without/external</p> 	DW	DIN 69871	SK 40	23
			SK 50	28
		DIN 69893 A	HKS 63	33
			HSK 100	38
		MAS-BT JIS 6339	BT 40	43
	BT 50	48		
	ANSI-CAT	CAT 40	53	
		CAT 50	58	
<p>90° Winkelkopf zurückversetzt Übersetzung $i = 1:1$ Kühlmittelzufuhr: ohne/extern/intern</p> <p>Angle Head 90° Offset Type Gear Ratio $i = 1:1$ Coolant supply: without/external/internal</p> 	ZW	DIN 69871	SK 40	24
			SK 50	29
		DIN 69893 A	HKS 63	34
			HSK 100	39
		MAS-BT JIS 6339	BT 40	44
	BT 50	49		
	ANSI-CAT	CAT 40	54	
		CAT 50	59	
<p>90° Winkelkopf zurückversetzt schmale Bauform Übersetzung $i = 1:1$ Kühlmittelzufuhr: ohne/extern</p> <p>Angle Head 90° Offset Slim Type Gear Ratio $i = 1:1$ Coolant supply: without/external</p> 	ZWS	DIN 69871	SK 40	25
			SK 50	30
		DIN 69893 A	HKS 63	35
			HSK 100	40
		MAS-BT JIS 6339	BT 40	45
	BT 50	50		
	ANSI-CAT	CAT 40	55	
		CAT 50	60	
<p>Winkelschwenkeinheit 0-98° Übersetzung $i = 1:1$ oder $1:2,25$ Kühlmittelzufuhr: intern</p> <p>Angle Head, Adjustable 0-98° Gear Ratio $i = 1:1$ or $1:2,25$ Coolant supply: internal</p> 	WS	DIN 69871	SK 40	26
			SK 50	31
		DIN 69893 A	HKS 63	36
			HSK 100	41
		MAS-BT JIS 6339	BT 40	46
	BT 50	51		
	ANSI-CAT	CAT 40	56	
		CAT 50	61	
<p>Winkelkopf mit festem Winkel</p> <p>Angle Head with Fixed Angle</p> 	FW	Auf Anfrage lieferbar. Available on request.		

Winkelbohr- und Fräsköpfe Angle Drilling Heads and Cutter Heads

mimatic® Winkelköpfe für die Komplettbearbeitung: Kein mehrmaliges Umspannen von Werkstücken mehr und somit eine deutliche Senkung der Produktionskosten, Rationalisierung und Schaffung von Flexibilität in der gesamten Fertigung. Winkelköpfe ermöglichen zudem die Bearbeitung unzugänglicher Stellen innerhalb von Gehäusen oder Bohrungen.

mimatic® Winkelköpfe sind in allen gängigen Maschinenkonzepten einsetzbar wie CNC-Bearbeitungszentren mit automatischem oder manuellem Werkzeugwechsel und Sondermaschinen mit festem Einsatz. Sie werden optimal auf die jeweilige Bearbeitungsaufgabe ausgelegt.

mimatic® angle heads for a complete, integrated machining: It is now no longer necessary to repeatedly relocate tools, which means a considerable reduction in production costs, rationalization and the increase in flexibility over the entire production process. They allow you to work on inaccessible areas within housings or bores.

mimatic® angle heads can be used in all popular machine concepts, such as CNC machining centers with automatic or manual tool change and special-purpose machines with fixed insert. They are optimally designed for the respective machining task.

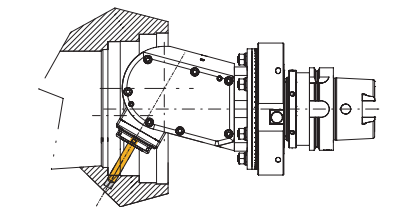
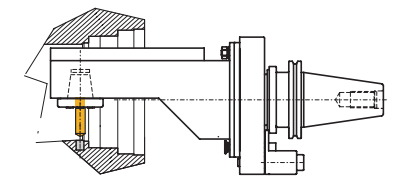
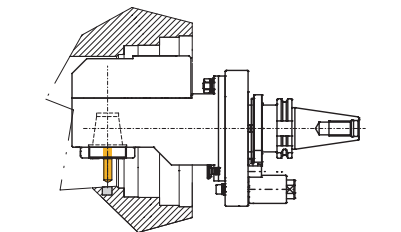
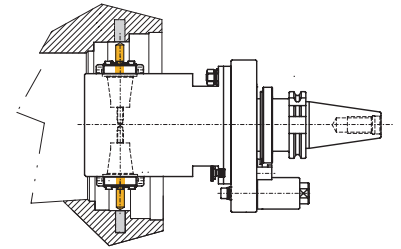
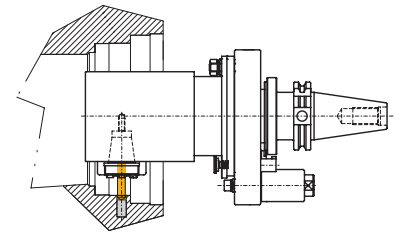

Merkmale der mimatic[®] Winkelköpfe Features of the mimatic[®] Angle Heads

Für ruhigen Lauf und hohe Kraftübertragung verwenden wir geschliffene und spiralverzahnte Kegelradgetriebe sowie gehärtete und geschliffene Stirnradgetriebe.

We use ground bevel gears with helical profile as well as hardened and ground spur gears to ensure smooth operation and high power transmission.

Ausführungen

- mimatic[®] Winkelköpfe sind in allen europäischen und internationalen Schaftvarianten lieferbar:
- **SK nach DIN 69871, ANSI-CAT, MAS-BT und**
- **HSK nach DIN 69893 - Form A**
- sowie weitere Normen und Größen auf Anfrage
- Mit **Standard-Drehmomentabstützung nach ISO 9524** (durch den Kunden anzupassen)
- Auf Wunsch mit maschinenangepasster 3-Punkt-Abstützung und Stoppblock
- Einwechseln automatisch oder von Hand
- Zum Bohren, Reiben, Senken, Gewinden und Fräsen
- Ermöglichen die Bearbeitung ansonsten unzugänglicher Werkstückbereiche (z.B. Innenbearbeitung)
- Zahlreiche Sonderkonstruktionen für komplizierte Bearbeitungsprobleme
- Ein-, zwei- oder mehrspindelige Varianten verfügbar
- Achsenwinkel gleich oder ungleich 90° oder einstellbar
- Auf Wunsch mit innerer Kühlmittelzufuhr durch die Spindel erhältlich (70 bar)
- Hohe Drehmomentübertragung
- Standardmäßig mit **Spannzangen Typ „ER“ nach DIN 6499 oder mit unserem modularem Werkzeug-Schnellwechselsystem „mi“** – passend dazu alle gängigen Werkzeugaufnahmen (Spannzangen, Weldon, Whistle-Notch, Hydrodehn, Schrumpffutter, Kombifräsdorn etc.)
- Mit mimatic[®] „SYNAX“-Gewinde-Schnellwechselfutter

Versions

- mimatic[®] angle heads are available in all European and international shank variants:
- **SK per DIN 69871, ANSI-CAT, MAS-BT and**
- **HSK to DIN 69893 – Form A**
- other standards and sizes are also available on request
- With **standard torque support according to ISO 9524** (to be adapted by the customer)
- Available on request with 3-point support adapted to the machine and stop block
- Tool changing manual or automatic
- For drilling, reaming, countersinking, threading and milling
- Allows the machining of sections of the workpiece which are otherwise inaccessible (e.g. internal machining)
- A large number of special, customized designs for complex machining problems
- Single, dual or multi-spindle variants are available
- Fixed angles can be made, as opposed to using Adjustables or standard 90° Heads
- Available on request with internal coolant supply via the spindle (70 bar)
- High torque transmission
- Available as **standard with collet chuck model „ER“ according to DIN 6499 or with our modular „mi“ quick-change tool system** – compatible with all popular tool fittings (collet chucks, Weldon, Whistle-Notch, hydraulic chucks, shrink fit chucks, combi milling arbors, etc.)
- with mimatic[®] „SYNAX“ thread quick-change chuck

mimatic „mi“

**Werkzeug-Schnellwechselsystem
Modular Quick-Change Tool System**



mimatic „SYNAX“

**Gewinde-Schnellwechselfutter
Tapping Quick-Change Holder**



Aufbau der mimatic® Winkelköpfe

Design of the mimatic® Angle Heads

- **Hochpräzisions-Spindellager Qualität P4** mit mittlerer Vorspannung (Lagerschmierung auf Lebensdauer) für hohe Drehzahlen geeignet (bis 15.000 U/min)
- **Hochsteife Spindellagerung** (innenliegende Werkzeugaufnahmespindel, d.h. Kraftangriffspunkt innerhalb des Gehäuses, somit geringe Hebelwirkung)
- **Kegelradsätze spiralverzahnt**
- **Dauerschmierung** des Getriebes mit Hochleistungsfett (wartungsarm)
- Möglichkeiten der **Kühlmittelzufuhr**:
 - **ohne**
 - **extern** über Spritzrohr
 - **intern** durch die Werkzeugaufnahme-spindel („i.K.“ – Paket mit Dichtbuchsen, gehärtete Gegenlaufscheiben, reibungsoptimierten Dichtungen und diversen O-Ringen)
- Einsatz von **reibungsoptimierten** Dichtungen mit PTFE Dichtlippe, für höhere Drehzahlen, Hoch-Temperaturbeständig
- **Lage der Mitnehmernuten zur Lage des Stoppblocks beliebig einstellbar** (0-360° mittels 6 Gewindestiften am Stellring)
- **Winkelkopf 360° drehbar und stufenlos einstellbar** – bei Winkelschwenkeinheiten zusätzlich 6 x 15° Indexierungen
- Hohe **Drehzahlen bis 15.000 U/min** und **hohe Drehmomente bis 150 Nm**
- Die **Drehmomentabstützung** ist **standardmäßig nach ISO 9524** ausgeführt. Diese kann **durch den Kunden selbst angepasst** werden.
- Zur Verfügung stehen verschiedene **Standard-Stoppblock** Ausführungen. Diese sind kundenseitig an die Werkzeugmaschine im Bedarfsfall anzupassen und anzubringen.
- **High-precision spindle bearing, P4 quality** with medium initial tension (lifetime lubrication of bearing), suitable for high speeds (up to 15,000 rpm)
- **Stabilized spindle bearing** (inside tool holding spindle, i.e. point of load incidence within the housing, therefore low leverage)
- **Bevel gear sets with helical profile**
- **Permanent lubrication** of the gear with heavy-duty lubricant (low-maintenance)
- Possibilities for **coolant supply**:
 - **without**
 - **external via coolant pipe**
 - **internal via tool holding spindle** („i.K.“ – package with packing sleeves, hardened upthrust washer, friction-optimized seals and various O-rings)
- Use of **friction-optimized** seals with PTFE sealing lips, for higher speeds, high temperature resistance
- **Output orientation is fully adjustable** (0–360° via the 6 setscrews on the adjusting ring)
- **Angle head can be rotated through 360° and is infinitely variable** – additional 6 x 15° index-ations for adjustable angle units
- **High speeds up to 15,000 rpm and high torques up to 150 Nm**
- **The torque support is designed according to ISO 9524 as standard.** This can be adapted by the customer
- Different **standard stop block** versions are available. If necessary, these are to be adapted and fitted to the machine tool by the customer.

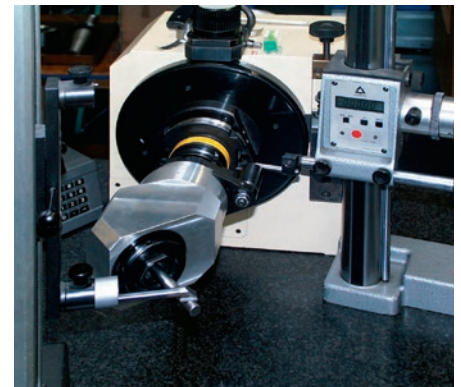
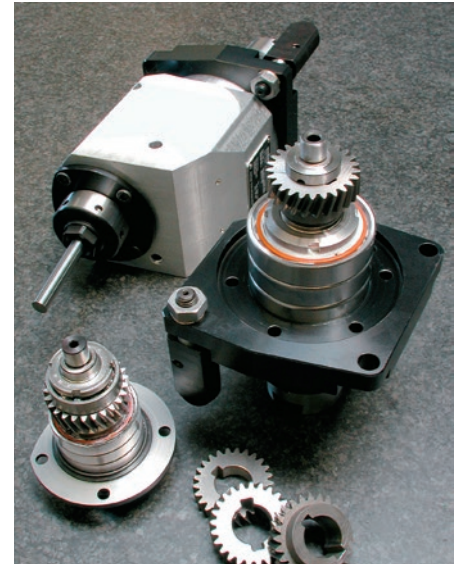

Leistungswerte Performance Values

Die nachfolgend angegebenen maximalen Drehmomente M_{max} beziehen sich auf eine stoßfreie Bearbeitung (z.B. Gewinde-schneiden). Bei stark stoßhaften Bearbeitungen (z.B. Fräsen) muss eine Reduzierung der zulässigen Werte um 50% und mehr berücksichtigt werden. Die angegebenen Werte für maximale Drehzahl n_{max} sind Anhaltswerte bei Kurzzeitbetrieb.

Die jeweils zulässige Einschaltdauer ist abhängig

- von der Ausführung der Angetriebenen Einheit
- vom Vorhandensein und Art der Kühlung (extern über Spritzdüse oder -rohr, bzw. intern durch die Werkzeugspindel)
- vom Bearbeitungsmoment

Bei einer Belastung von ca. 60% der Maximalwerte ergibt sich eine rechnerische Lebensdauer von ca. 2000 Betriebsstunden. Angetriebene Einheiten mit Getriebe haben bei höheren Drehzahlen eine erhöhte Temperatur- und Geräusentwicklung.

The torques M_{max} specified in the tables below refer to shock-free processing (e.g. threaded cutting). For processes involving major shock loads (e.g. milling or multi-edge knocking), a value reduction of up to 50% and more needs to be taken into account.

The values n_{max} and P_{max} rendered are guideline values for short-time operation.

The permissible relative operating duration depends

- on the version of the spindle unit (with or without gear)
- on the presence of a cooling system and the type of cooling (external or internal through the tool spindle)
- on the processing torque

At a charge of about 60% of the maximum values the working life calculated amounts to approx. 2000 hours Spindle units with gears produce more noise at higher speeds!

Betriebshinweise

Erstinbetriebnahme: Für eine lange Lebensdauer des Werkzeuges ist es wichtig, einen Einlaufvorgang durchzuführen. Dieser Vorgang dient dazu, die innere Reibung in der angetriebenen Einheit zu reduzieren und das Fett in den Präzisionslagern gleichmäßig zu verteilen.

- Lassen Sie das Werkzeug die erste Betriebsstunde mit 70% der maximal zulässigen Drehzahl laufen.
- Betreiben Sie das Werkzeug niemals oberhalb des maximal zulässigen Drehmoments und/oder der maximal zulässigen Drehzahl (Maßzeichnung).

Werkzeuge mit innerer Kühlmittelzufuhr (i.K.): Zur Vermeidung von vorzeitigem Verschleiß und der Zerstörung des Dichtungssystems empfehlen wir, den Kühlschmierstoff zu filtern. Filterfeinheiten von 40 μm haben sich in der Praxis sehr bewährt. Die maximal zulässigen Kühlschmierstoffdrücke entnehmen Sie bitte den technischen Daten der angetriebenen Werkzeugeinheit.

Operating Instructions

Initial Start-up: To ensure long tool life it is important to properly "run-in" the tools. This procedure serves to reduce the internal friction in the driven unit and to evenly distribute the grease in the precision bearings.

- Max. RPM in the first operation hour should not exceed 70% of the maximum permissible RPM.
- Never run the tool above the maximum permissible torque rate and/or maximum permissible RPM (see also the drawing of the unit).

Tools with internal coolant through the spindle (i.C.): To avoid premature wear and damage to the seal system we recommend to filter the coolant to 40 μm minimum. Filter grades of 40 μm worked in operation with very good results. The maximum permissible coolant pressure can be taken from the technical data of the driven toolholder. Driven Toolholders with internal coolant

Angetriebene Werkzeuge mit innerer Kühlmittelzufuhr (i.K.) sollen nie ohne Kühlschmierstoff betrieben werden. Der Kühlschmierstoff muss durch das Werkzeug fließen, bevor der Werkzeugantrieb eingeschaltet wird. Trockenlauf zerstört die inneren Dichtungen.

Serviceintervall: Die Lebensdauer von angetriebenen Werkzeugen hängt stark von dem Einsatzfall ab. Regelmäßig müssen Verschleißteile, wie z.B. Lager und Dichtungen, ausgetauscht werden. Wir empfehlen, die Werkzeuge mindestens einmal jährlich an unser Servicecenter zur vollständigen Reinigung und Neubefettung zu schicken. Bei Werkzeugen mit innerer Kühlschmierstoffzufuhr sollte das Serviceintervall auf 6 Monate reduziert werden.

through the spindle (i.C.) should never run without coolant. The coolant should flow through the tool, before the tool drive is switched on. Running in dry condition damages the internal seals.

Service interval: The tool life of the driven toolholder depends strongly on the application. Wear parts such as bearings and seals should be exchanged. We recommend to send the tools at least once annually to our service center for cleaning and regreasing. Tools with internal coolant through the spindle should be serviced every 6 months.

Aufbau der Standard-Winkelköpfe

Features of the Standard Angle Heads

- **Hochpräzise Lagertechnik**
- **Hohe Rundlaufgenauigkeit**
- **Hohe Steifigkeit**

mimatic® Winkelköpfe werden technisch so ausgeführt, dass die Qualität Ihrer Werkstücke und die Standzeit Ihrer Werkzeuge steigt.

- **High-precision Bearing Technology**
- **High Concentricity**
- **High Rigidity**

mimatic® angle heads are designed in such a way that they increase the quality of your workpieces and the service life of your tools.

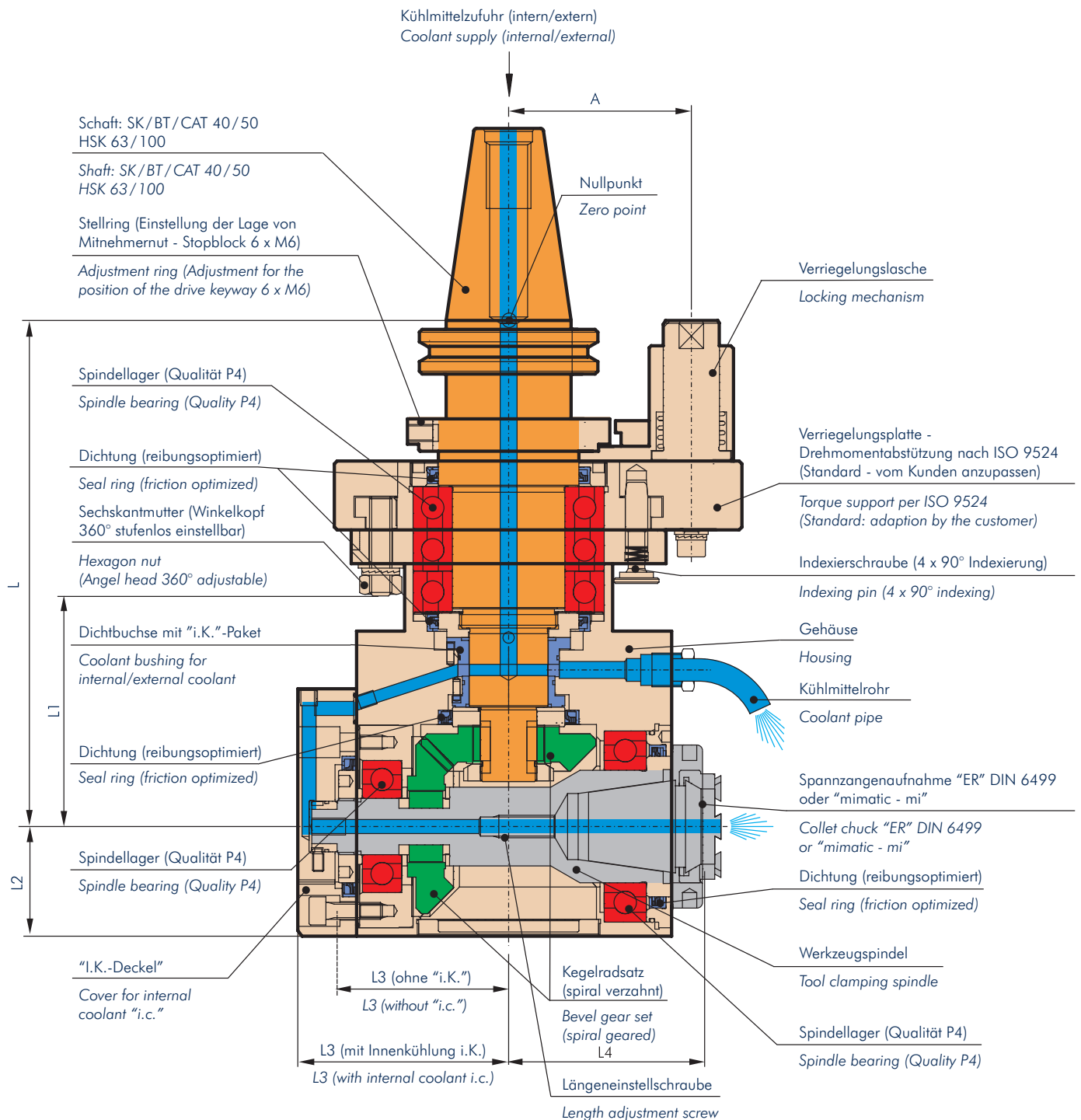

SK 40

SW

Winkelkopf 90° Angle Head 90°

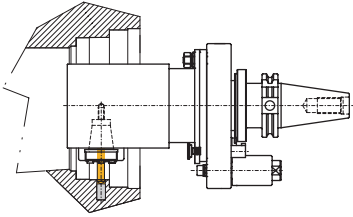

Für einzelne Bohr- und Fräsoperationen ohne räumliche Beschränkungen.

For single boring and milling operations without clearance issues.



Achtung:
Drehrichtungsumkehr

Attention!
Reversal of rotation
direction

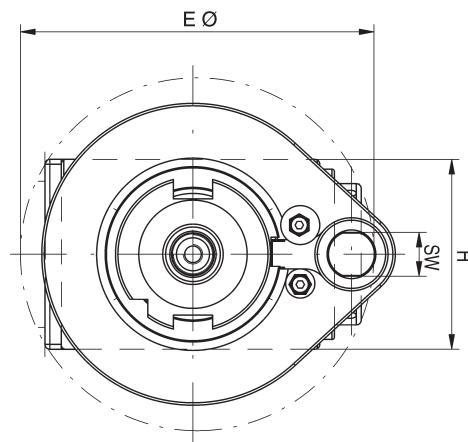
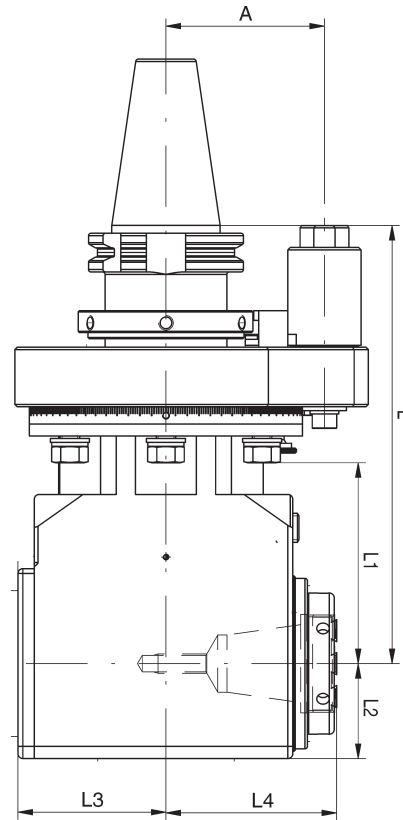
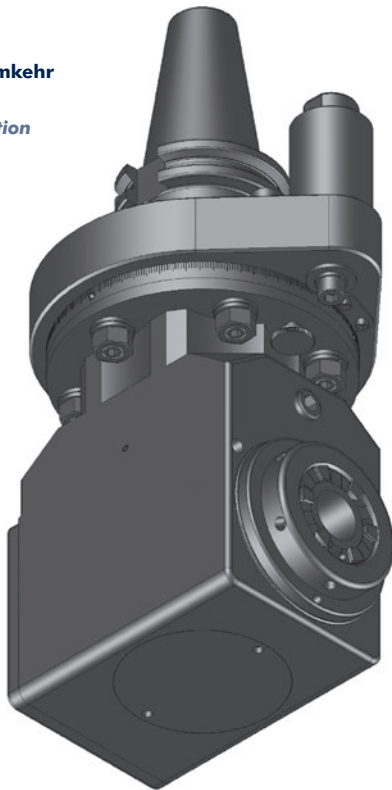

Baugröße Size	Bestell-Nr. / Order No.			Werkzeug Aufnahme Toolholder	Eintauch / Clearance Ø E mm		L3 mm		L4 mm	
	ohne / without	extern / external	intern / internal							
1	105485	105679	105695	ER 16	91	96	29,0	44	45,0	50
5	105493	162767	105507	ER 25	110	120	41,5	52	57,5	63
5	105490	162799	105513	mi 40	138	146	41,5	52	72,0	72
7	135486	105516	105539	ER 32	145	155	61,0	75	70,0	75
7	135453	162790	162791	mi 50	172	178	61,0	75	83,0	83

Baugröße Size	max. Drehmoment Torque max.	max. Drehzahl (U/min.) Rev. max. (RPM)	Übersetzung Gear Ratio	L mm	L1 mm	L2 mm	H mm	A mm	kg	SW
1	12 Nm	10.000	i = 1:1	180	80	22	44	65	6,0	18
5	30 Nm	8.000	i = 1:1	180	80	34	68	65	6,5	18
7	70 Nm	6.500	i = 1:1	180	80	39	78	65	8,0	18

SK 40

DW

Doppel-Winkelkopf 90° Double Angle Head 90°

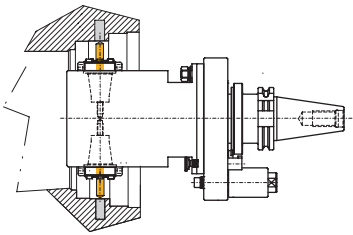

Doppelspindler um zwei entgegengesetzte Bohr- und Fräsoperationen durchführen zu können.

Double spindle unit to do two boring and milling operations in opposite directions.

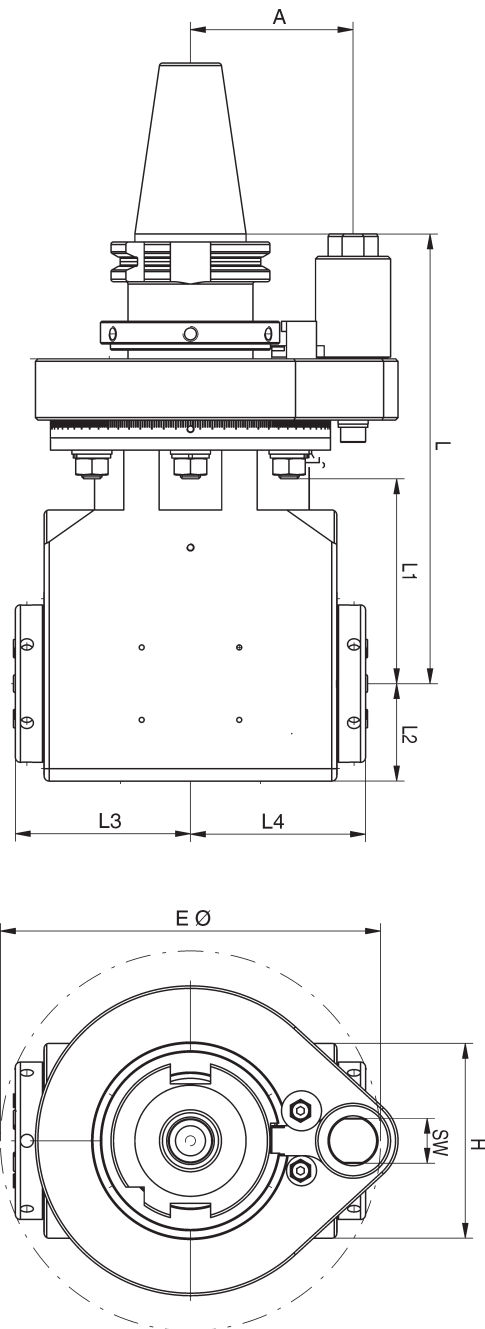
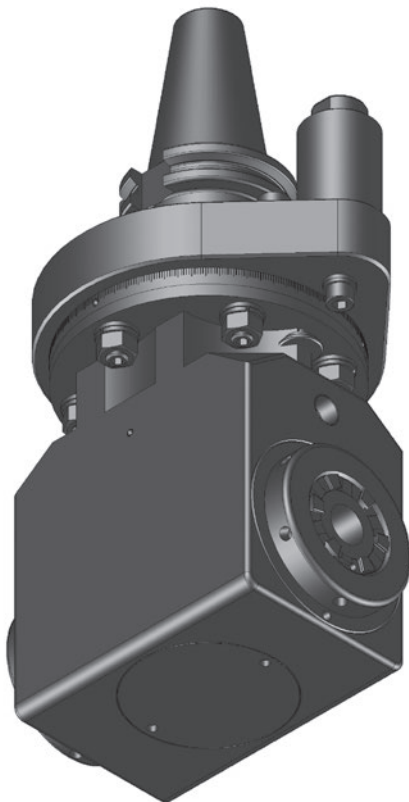

Baugröße Size	Bestell-Nr. / Order No.			Werkzeug Aufnahme Toolholder	Eintauch / Clearance Ø E mm		L3 mm		L4 mm	
	ohne / without	extern / external	intern / internal							
5	135710	168317		2 x ER 25	125	125	62,0	62,0	62,0	62,0
5	173507	162838		2 x mi 32	200	200	76,5	76,5	76,5	76,5
7	135733	166009		2 x ER 32	152	152	71,2	71,2	71,2	71,2
7	105775	174400		2 x mi 40	220	220	88,0	88,0	88,0	88,0

Baugröße Size	max. Drehmoment Torque max.	max. Drehzahl (U/min.) Rev. max. (RPM)	Übersetzung Gear Ratio	L mm	L1 mm	L2 mm	H mm	A mm	kg	SW
5	30 Nm	8.000	i = 1:1	180	80	39	78	65	7,5	18
7	70 Nm	6.500	i = 1:1	180	80	39	78	65	8,5	18

SK 40

ZW

Winkelkopf 90° zurückversetzt Angle Head 90°, Offset Type

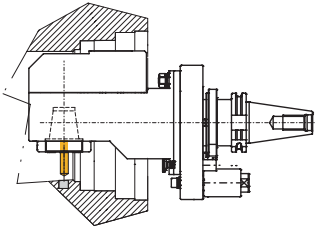

Zurückgesetzte Einheit mit vergrößerter nutzbarer Werkzeuglänge und Innenkühlung als Option.

Rear offset unit with increased usable tool length and internal coolant is an option.

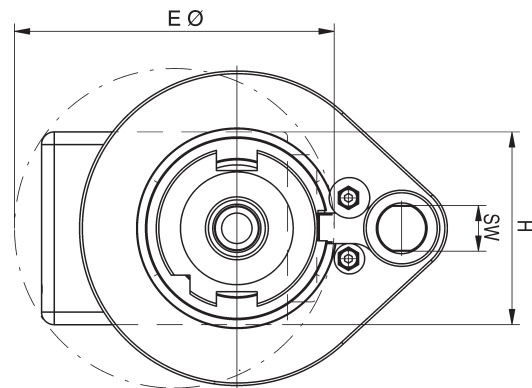
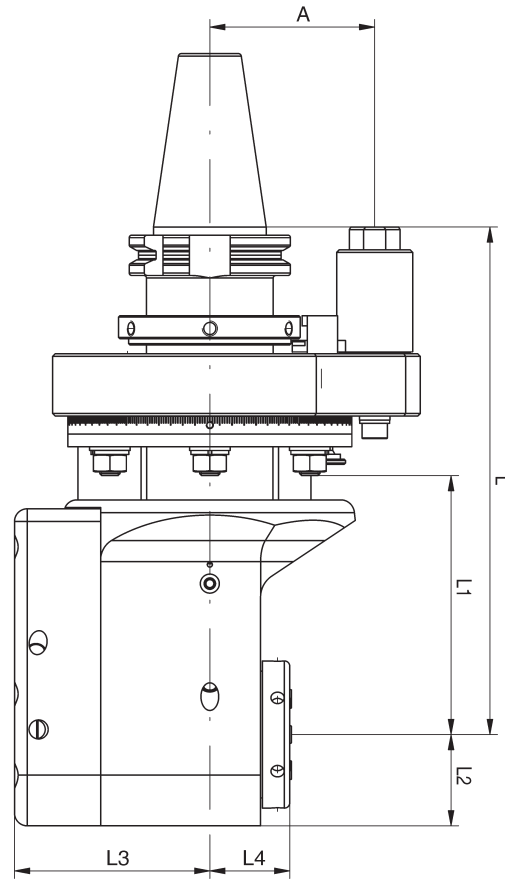
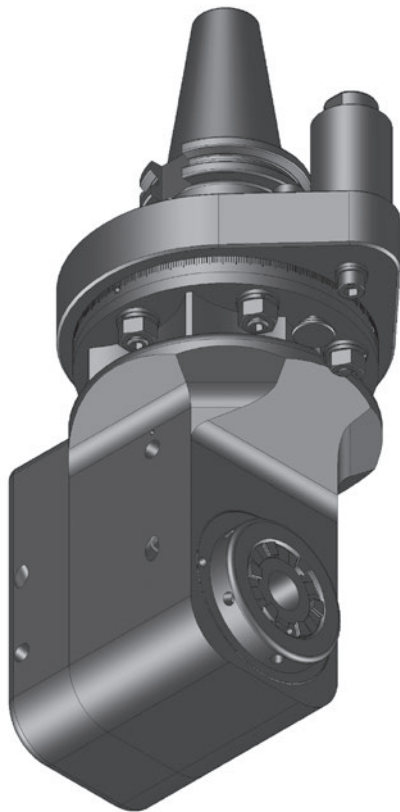

Baugröße Size	Bestell-Nr. / Order No.			Werkzeug Aufnahme Toolholder	Eintauch / Clearance Ø E mm		L3 mm		L4 mm	
	ohne / without	extern / external	intern / internal							
5	135389	162855	168670	ER 25	103	103	57,0	57,0	35,8	41,6
5	105439	162879	162880	mi 40	130	130	57,0	57,0	50,3	50,3
7	105440	162868	105478	ER 32	128	128	77,5	77,5	32,2	38,0
7	105429	162894	162895	mi 50	150	150	77,5	77,5	55,0	55,0

Baugröße Size	max. Drehmoment Torque max.	max. Drehzahl (U/min.) Rev. max. (RPM)	Übersetzung Gear Ratio	L mm	L1 mm	L2 mm	H mm	A mm	kg	SW
5	30 Nm	8.000	i = 1:1	180	80	28,5	57	65	6,5	18
7	70 Nm	6.500	i = 1:1	198	100	38,0	76	65	8,5	18

SK 40

ZWS

Winkelkopf 90° zurückversetzt schmale Bauform Angle Head 90°, Offset Slim Type

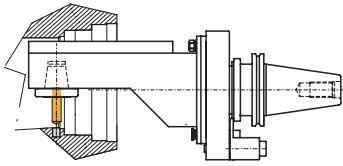

Zurückversetzte und schmale Bauform zum Eintauchen in kleine Bohrungen oder eingegengten Platzverhältnissen.

Offset narrow form to slide into small bores or when clearance issues / space restrictions are issue.



Achtung:
Drehrichtungsumkehr

Attention!
Reversal of rotation
direction

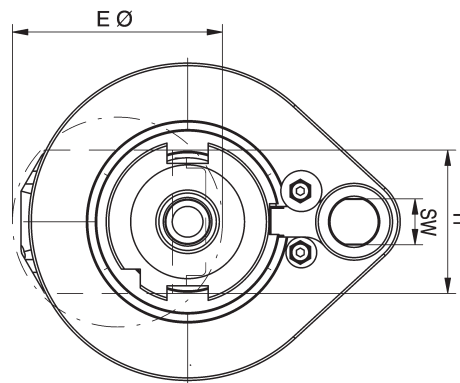
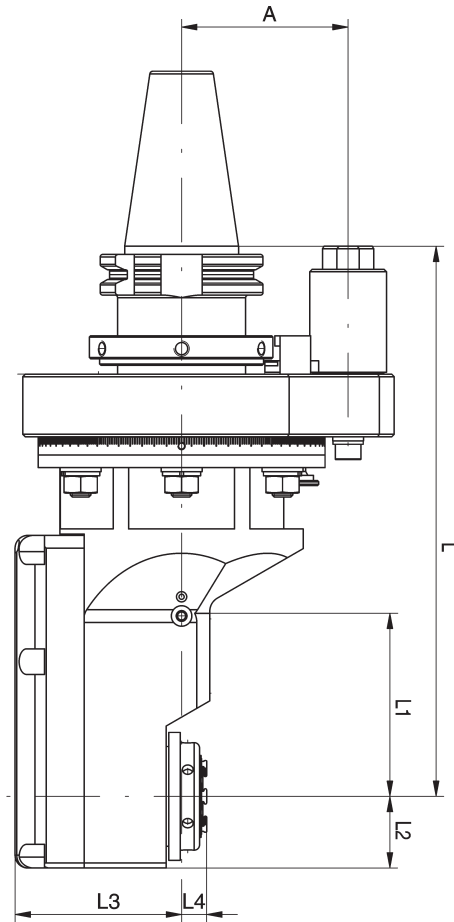
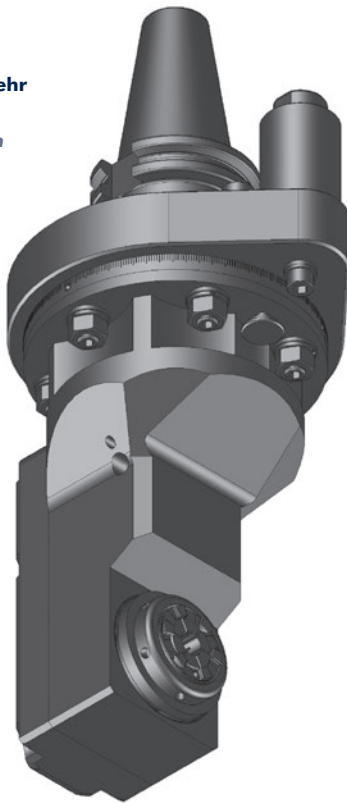

Baugröße Size	Bestell-Nr. / Order No.			Werkzeug Aufnahme Toolholder	Eintauch / Clearance Ø E mm		L3 mm		L4 mm	
	ohne / without	extern / external	intern / internal							
0	105631			ER 11	50		49,0		-8,0	
3	105665			ER 20	75		54,5		11,2	
3	173535			mi 32	100		54,5		26,0	
5	135615	162922		ER 25	82	82	65,0	65	10,0	10,0
5	135609	162934		mi 40	125	125	65,0	65	23,5	23,5

Baugröße Size	max. Drehmoment Torque max.	max. Drehzahl (U/min.) Rev. max. (RPM)	Übersetzung Gear Ratio	L mm	L1 mm	L2 mm	H mm	A mm	kg	SW
0	6 Nm	12.000	i = 1:1,67	213	38	20	36	65	7,0	18
3	15 Nm	10.000	i = 1:1	225	80	24	48	65	6,0	18
5	30 Nm	8.000	i = 1:1	215	76	28	56	65	6,5	18

SK 40

WS

Winkelschwenkeinheit 0-98° Angle Head, Adjustable 0-98°

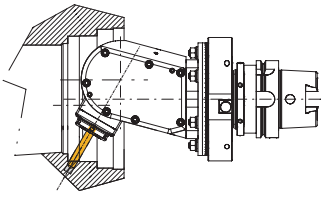

Einstellbare Winkelschwenkeinheit, um Bohr- und Fräsarbeiten in allen Winkeln durchführen zu können.

Adjustable angle unit to do boring and milling applications at any angle.

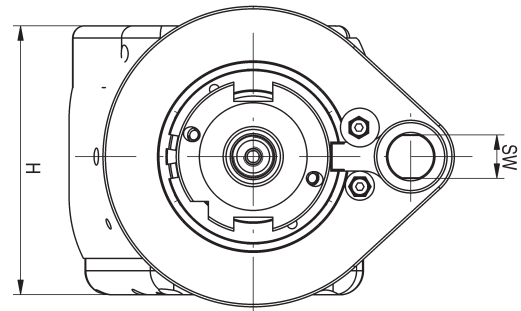
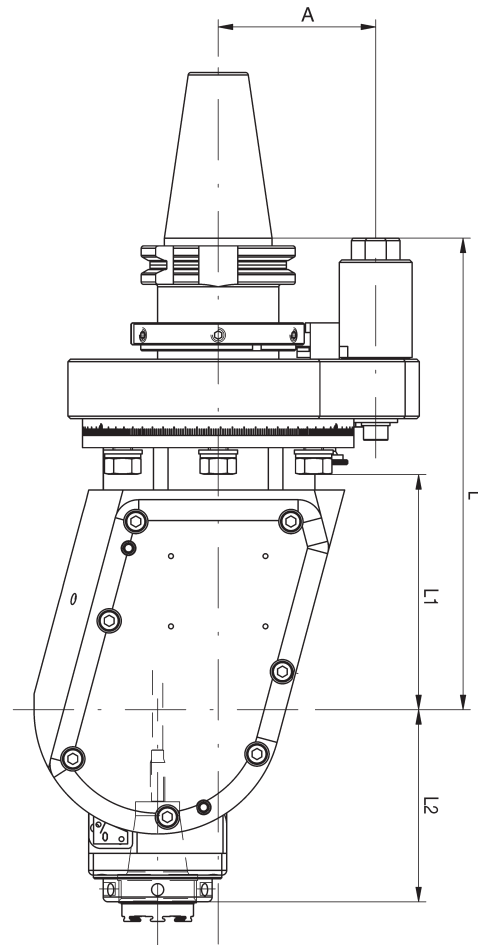
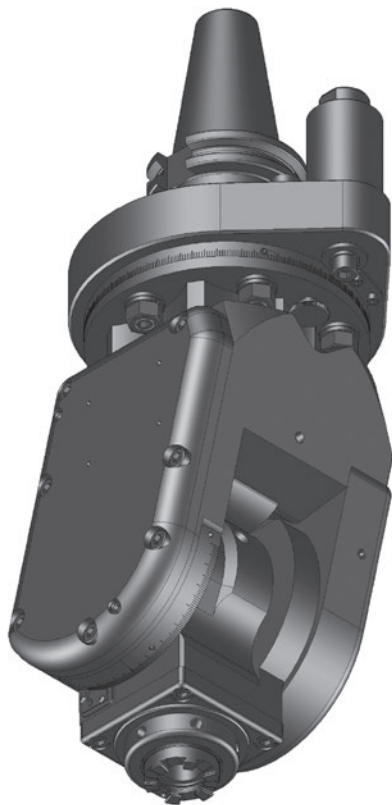

Baugröße Size	Bestell-Nr. / Order No. (i=1:1)		Bestell-Nr. / Order No. (i=1:2,25)		Werkzeug Aufnahme Toolholder	L2 mm	L4 mm
	ohne / without	intern / internal	ohne / without	intern / internal			
3	162793	105825	156560	105823	ER 20	75,0	20
3	156561	105832	156562	156563	mi 32	82,9	20
5	174413	105833	156580	105826	ER 25	84,0	25
5	162952	169975	162953	162954	mi 40	97,0	25

Baugröße Size	max. Drehmoment Torque max.	max. Drehzahl (U/min.) Rev. max. (RPM)	Übersetzung Gear Ratio	L mm	L1 mm	H mm	A mm	kg	SW
3	15 Nm	8.000 / 15.000	i = 1:1 / 1:2,25	189	91	96	65	8,0	18
5	30 Nm	7.000 / 13.500	i = 1:1 / 1:2,25	195	96	111	65	9,6	18

SK 50

SW

Winkelkopf 90° Angle Head 90°

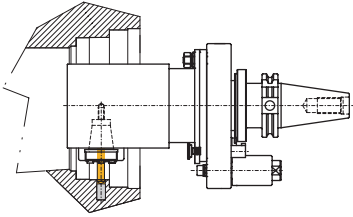

Für einzelne Bohr- und Fräsoperationen ohne räumliche Beschränkungen.

For single boring and milling operations without clearance issues.



Achtung:
Drehrichtungsumkehr

Attention!
Reversal of rotation
direction

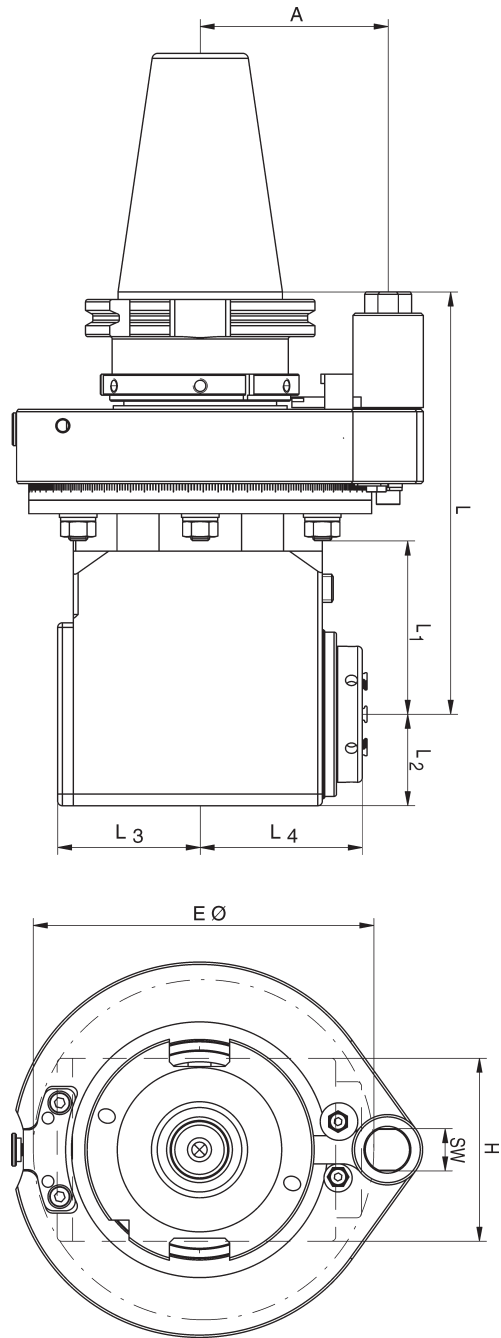
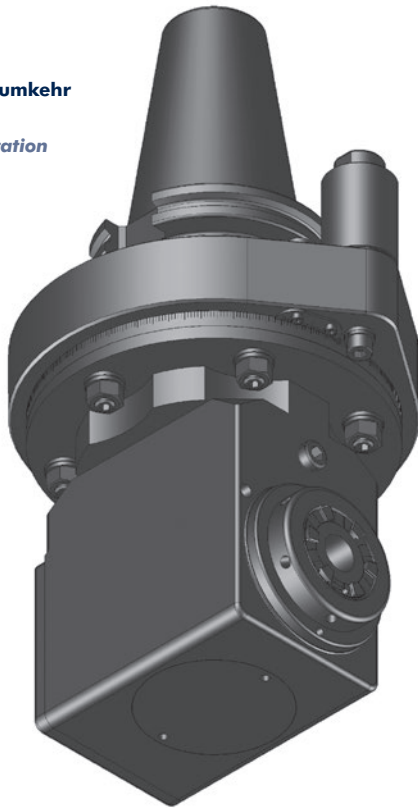

Baugröße Size	Bestell-Nr. / Order No.			Werkzeug Aufnahme Toolholder	Eintauch / Clearance Ø E mm		L3 mm		L4 mm	
	ohne / without	extern / external	intern / internal							
5	135458	135446	135447	ER 25	110	120	41,5	52	57,5	63,0
5	167870	162806	105500	mi 40	138	146	41,5	52	72,0	72,0
7	135476	162778	166720	ER 32	145	155	61,0	75	70,0	75,0
7	105519	162795	105522	mi 50	172	178	61,0	75	83,0	83,0
9	105551	162780	169469	ER 40	195	195	81,0	81	92,0	96,0
9	173083	162784	166543	mi 63	224	224	81,0	81	111,5	111,5

Baugröße Size	max. Drehmoment Torque max.	max. Drehzahl (U/min.) Rev. max. (RPM)	Übersetzung Gear Ratio	L mm	L1 mm	L2 mm	H mm	A mm	kg	SW
5	30 Nm	8.000	i = 1:1	180	75	34	68	80	10,5	18
7	70 Nm	6.500	i = 1:1	180	75	39	78	80	12,0	18
9	150 Nm	5.000	i = 1:1	215	105	52	104	80	18,0	18

SK 50

DW

Doppel-Winkelkopf 90° Double Angle Head 90°

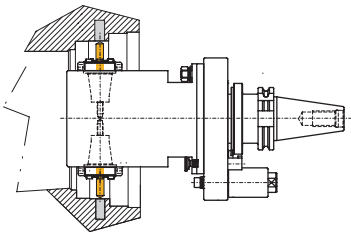

Doppelspindel um zwei entgegengesetzte Bohr- und Fräsoperationen durchführen zu können.

Double spindle unit to do two boring and milling operations in opposite directions.

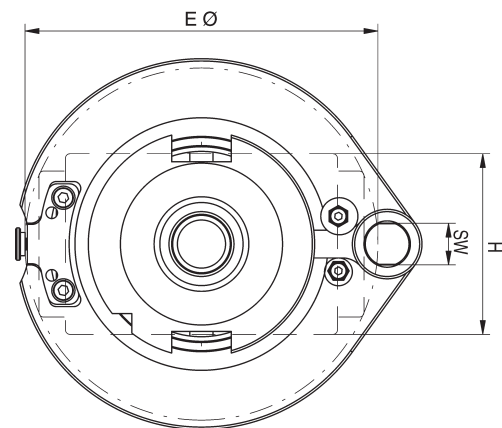
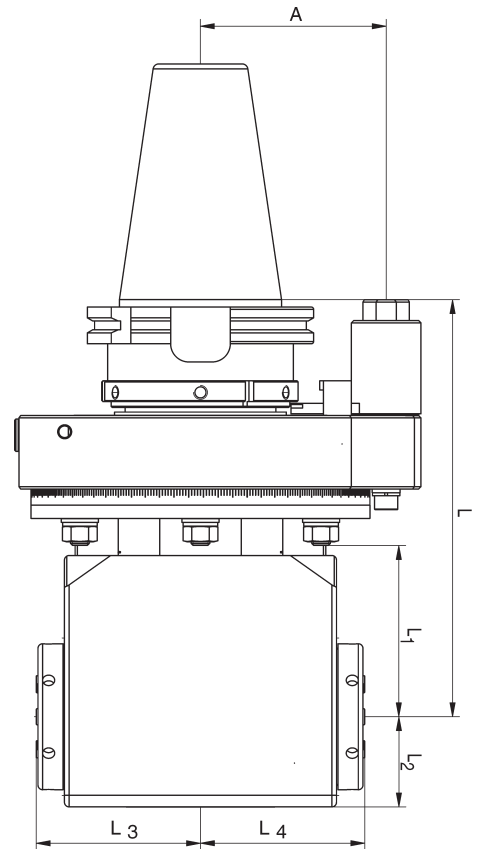
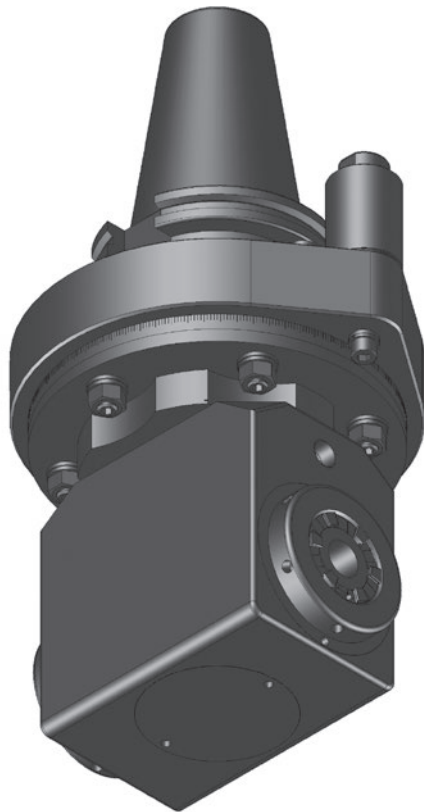

Baugröße Size	Bestell-Nr. / Order No.			Werkzeug Aufnahme Toolholder	Eintauch / Clearance Ø E mm		L3 mm		L4 mm	
	ohne / without	extern / external	intern / internal							
5	135678	162825		2 x ER 25	125	125	62,0	62,0	62,0	62,0
5	173511	162842		2 x mi 32	200	200	76,5	76,5	76,5	76,5
7	135734	167532		2 x ER 32	152	152	71,2	71,2	71,2	71,2
7	167238	105776		2 x mi 40	220	220	88,0	88,0	88,0	88,0
9	105784	162834		2 x ER 40	210	210	103,0	103,0	103,0	103,0
9	167654	162851		2 x mi 50	250	250	116,0	116,0	116,0	116,0

Baugröße Size	max. Drehmoment Torque max.	max. Drehzahl (U/min.) Rev. max. (RPM)	Übersetzung Gear Ratio	L mm	L1 mm	L2 mm	H mm	A mm	kg	SW
5	30 Nm	8.000	i = 1:1	180	70	34	68	80	11,5	18
7	70 Nm	6.500	i = 1:1	180	70	39	78	80	13,5	18
9	150 Nm	4.000	i = 1:1	215	109	58	108	80	20,0	18

SK 50

ZW

Winkelkopf 90° zurückversetzt Angle Head 90°, Offset Type

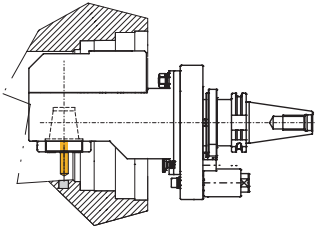

Zurückgesetzte Einheit mit vergrößerter nutzbarer Werkzeuglänge und Innenkühlung als Option.

Rear offset unit with increased usable tool length and internal coolant is an option.

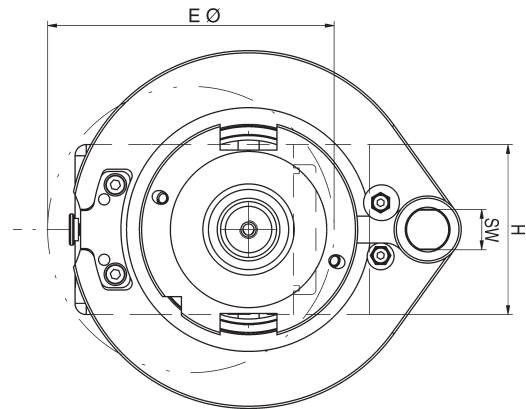
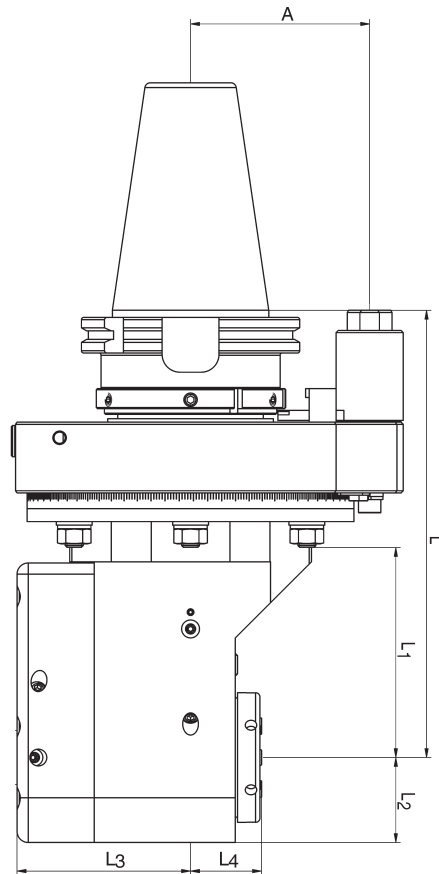
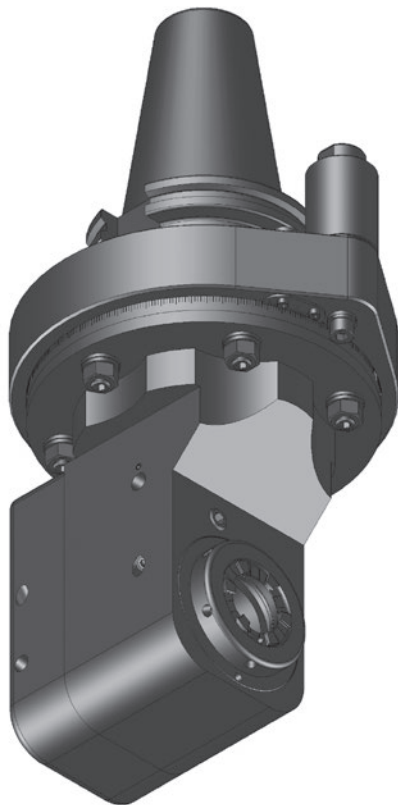

Baugröße Size	Bestell-Nr. / Order No.			Werkzeug Aufnahme Toolholder	Eintauch / Clearance Ø E mm		L3 mm		L4 mm	
	ohne / without	extern / external	intern / internal							
5	105416	162861	162862	ER 25	103	103	58,0	58,0	35,8	41,6
5	173523	162886	162887	mi 40	133	133	58,0	58,0	50,3	50,3
7	105430	162871	105479	ER 32	128	128	77,5	77,5	32,2	38,0
7	169908	162900	105475	mi 50	152	152	77,5	77,5	55,0	55,0
9	105482	162874	162876	ER 40	140	140	89,0	89,0	31,0	34,8
9	105468	162904	162905	mi 63	165	165	89,0	89,0	48,3	48,3

Baugröße Size	max. Drehmoment Torque max.	max. Drehzahl (U/min.) Rev. max. (RPM)	Übersetzung Gear Ratio	L mm	L1 mm	L2 mm	H mm	A mm	kg	SW
0	30 Nm	8.000	i = 1:1	185	79	28,5	57	80	11,5	18
3	70 Nm	6.000	i = 1:1	200	94	38,0	76	80	14,0	18
5	150 Nm	5.000	i = 1:1	260	152	52,0	104	80	19,0	18

SK 50

ZWS

Winkelkopf 90° zurückversetzt schmale Bauform Angle Head 90°, Offset Slim Type

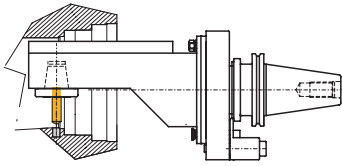

Zurückversetzte und schmale Bauform zum Eintauchen in kleine Bohrungen oder eingegengten Platzverhältnissen.

Offset narrow form to slide into small bores or when clearance issues / space restrictions are issue.



Achtung:
Drehrichtungsumkehr

Attention!
Reversal of rotation
direction

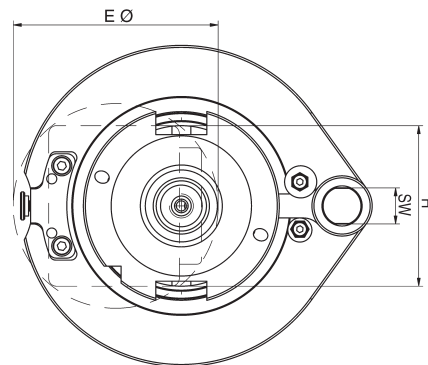
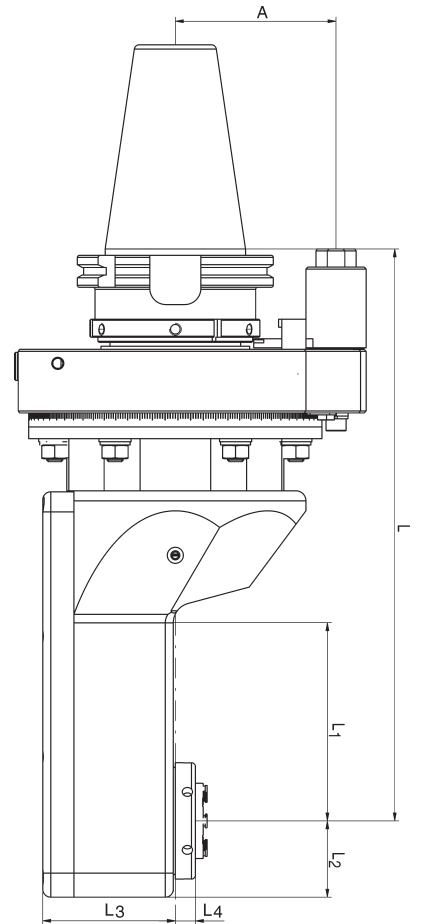
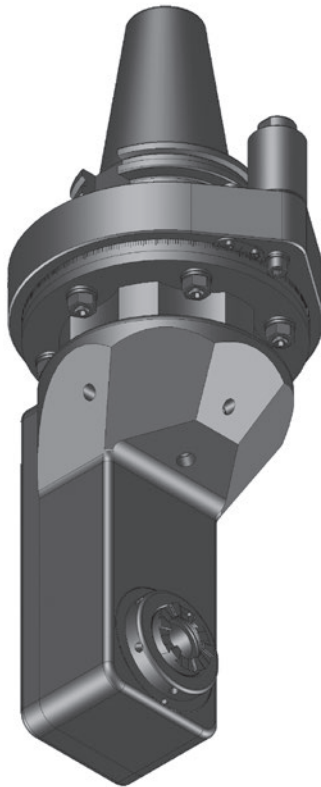

Baugröße Size	Bestell-Nr. / Order No.			Werkzeug Aufnahme Toolholder	Eintauch / Clearance Ø E mm		L3 mm		L4 mm	
	ohne / without	extern / external	intern / internal							
0	105650			ER 11	50		49		-8,0	
5	105682	162926		ER 25	82	82	65	65	10,0	10,0
5	173539	162938		mi 40	125	125	65	65	23,5	23,5
7	135643	105684		ER 32	102	102	66	66	13,0	13,0
7	167741	162942		mi 50	135	135	66	66	29,0	29,0

Baugröße Size	max. Drehmoment Torque max.	max. Drehzahl (U/min.) Rev. max. (RPM)	Übersetzung Gear Ratio	L mm	L1 mm	L2 mm	H mm	A mm	kg	SW
0	6 Nm	12.000	i = 1:1,67	227,5	38	20	36	80	11,0	18
5	30 Nm	8.000	i = 1:1	215,0	76	28	56	80	12,5	18
7	70 Nm	6.000	i = 1:1	285,0	100	38	80	80	13,5	18

SK 50

WS

Winkelschwenkeinheit 0-98° Angle Head, Adjustable 0-98°

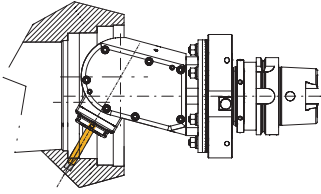

Einstellbare Winkelschwenkeinheit, um Bohr- und Fräsarbeiten in allen Winkeln durchführen zu können.

Adjustable angle unit to do boring and milling applications at any angle.

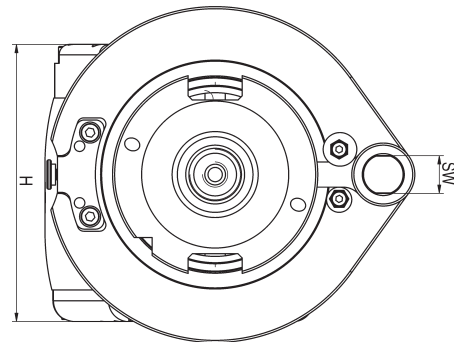
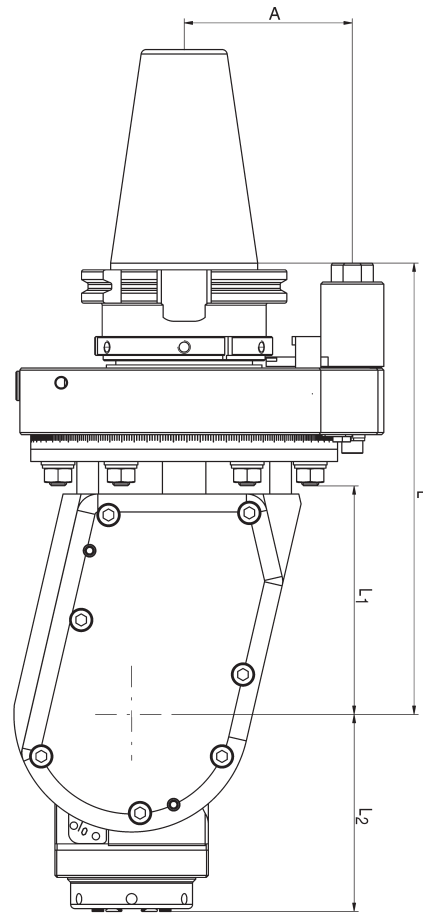
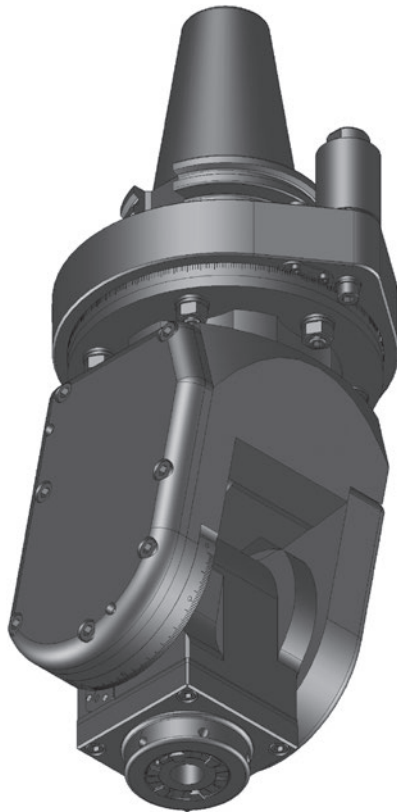

Baugröße Size	Bestell-Nr. / Order No. (i=1:1)		Bestell-Nr. / Order No. (i=1:2,25)		Werkzeug Aufnahme Toolholder	L2 mm	L4 mm
	ohne / without	intern / internal	ohne / without	intern / internal			
5	162965	135816	135823	162966	ER 25	84	25
5	162967	167021	162968	162969	mi 40	97	25
7	162982	105864			ER 32	95	25
7	162989	166981			mi 50	108	25

Baugröße Size	max. Drehmoment Torque max.	max. Drehzahl (U/min.) Rev. max. (RPM)	Übersetzung Gear Ratio	L mm	L1 mm	H mm	A mm	kg	SW
5	30 Nm	7.000 / 13.500	i = 1:1 / 1:2,25	195	96	111	80	14,0	18
7	70 Nm	6.000	i = 1:1	215	108	132	80	16,0	18

HSK 63

SW

Winkelkopf 90° Angle Head 90°

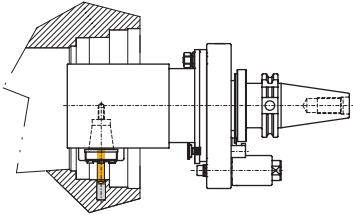

Für einzelne Bohr- und Fräsoperationen ohne räumliche Beschränkungen.

For single boring and milling operations without clearance issues.



Achtung:
Drehrichtungsumkehr

Attention!
Reversal of rotation direction

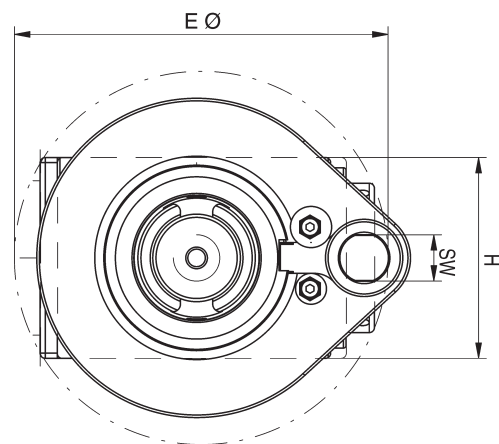
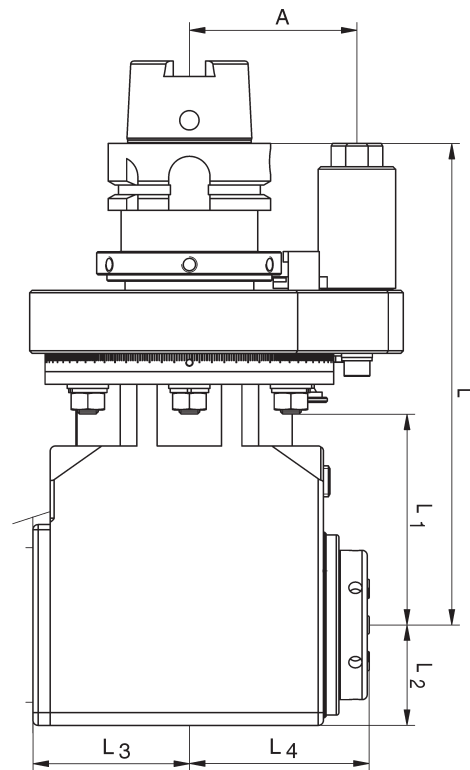
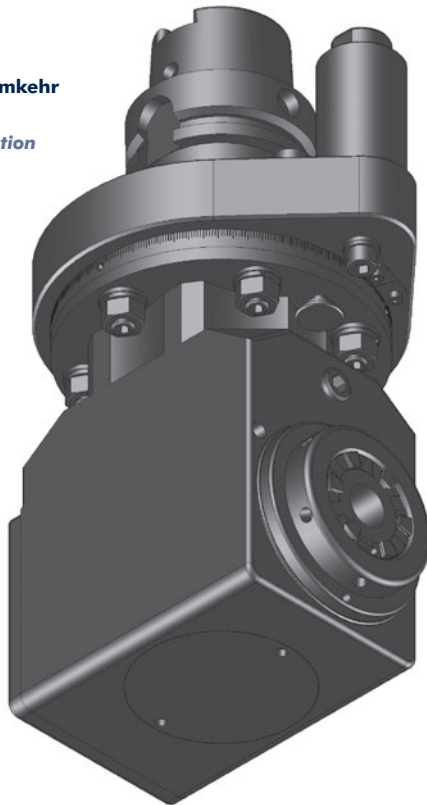

Baugröße Size	Bestell-Nr. / Order No.			Werkzeug Aufnahme Toolholder	Eintauch / Clearance Ø E mm		L3 mm		L4 mm	
	ohne / without	extern / external	intern / internal							
1	135456	162792	135452	ER 16	91	96	29,0	44	45,0	50
5	135433	105491	105501	ER 25	110	120	41,5	52	57,5	63
5	169846	162804	162805	mi 40	138	146	41,5	52	72,0	72
7	135489	105528	105533	ER 32	145	155	61,0	75	70,0	75
7	105504	162794	105540	mi 50	172	178	61,0	75	83,0	83

Baugröße Size	max. Drehmoment Torque max.	max. Drehzahl (U/min.) Rev. max. (RPM)	Übersetzung Gear Ratio	L mm	L1 mm	L2 mm	H mm	A mm	kg	SW
1	12 Nm	10.000	i = 1:1	187	80	22	44	65	6,0	18
5	30 Nm	8.000	i = 1:1	187	80	34	68	65	6,5	18
7	70 Nm	6.500	i = 1:1	187	80	39	78	65	8,0	18

HSK 63

DW

Doppel-Winkelkopf 90° Double Angle Head 90°

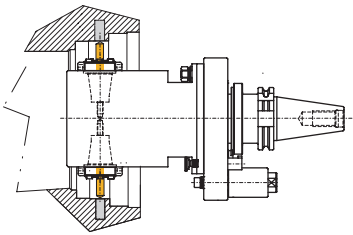

Doppelspindler um zwei entgegengesetzte Bohr- und Fräsoperationen durchführen zu können.

Double spindle unit to do two boring and milling operations in opposite directions.

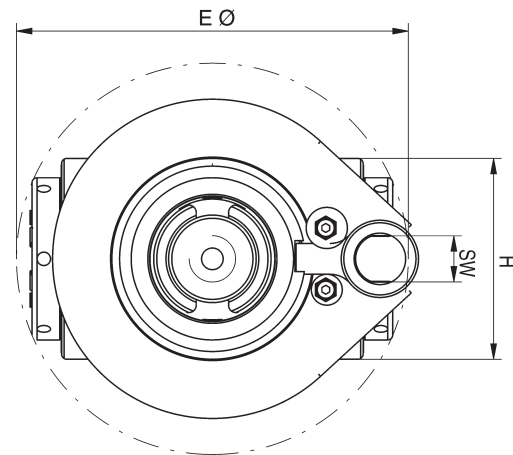
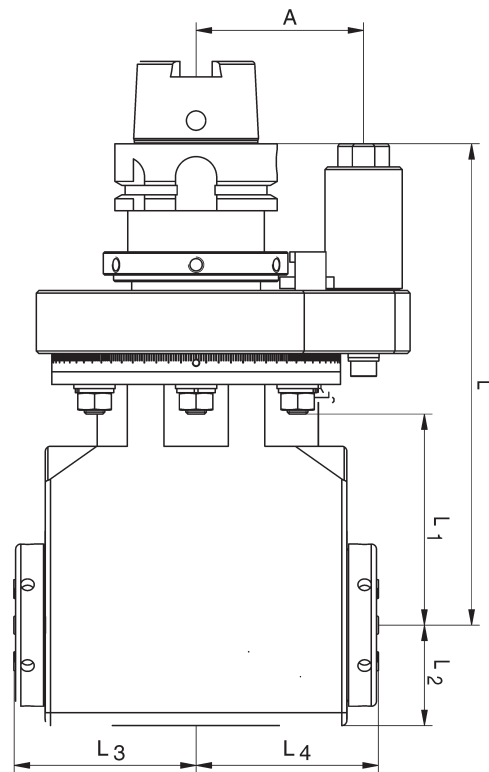
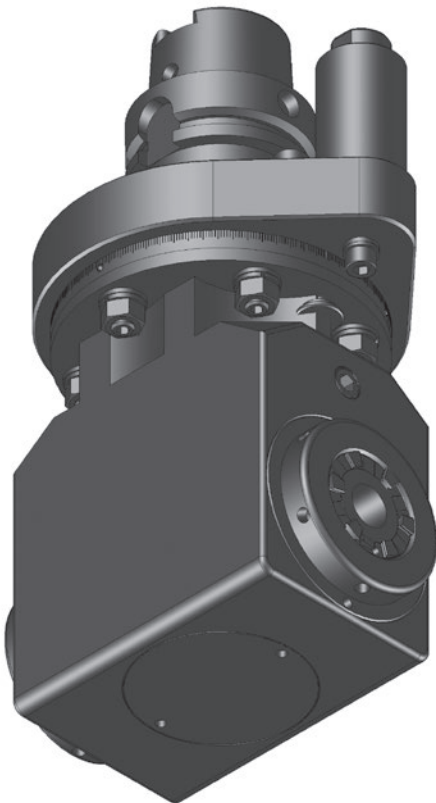

Baugröße Size	Bestell-Nr. / Order No.			Werkzeug Aufnahme Toolholder	Eintauch / Clearance Ø E mm		L3 mm		L4 mm	
	ohne / without	extern / external	intern / internal							
5	135706	162824		2 x ER 25	125	125	62,0	62,0	62,0	62,0
5	173510	162841		2 x mi 32	200	200	76,5	76,5	76,5	76,5
7	135747	162830		2 x ER 32	152	152	71,2	71,2	71,2	71,2
7	170454	176644		2 x mi 40	220	220	88,0	88,0	88,0	88,0

Baugröße Size	max. Drehmoment Torque max.	max. Drehzahl (U/min.) Rev. max. (RPM)	Übersetzung Gear Ratio	L mm	L1 mm	L2 mm	H mm	A mm	kg	SW
5	30 Nm	8.000	i = 1:1	187	80	39	78	65	7,5	18
7	70 Nm	6.500	i = 1:1	187	80	39	78	65	8,5	18

HSK 63

ZW

Winkelkopf 90° zurückversetzt Angle Head 90°, Offset Type

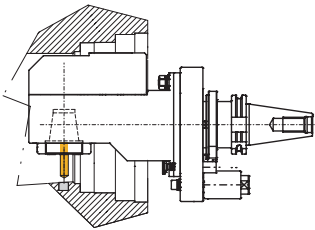

Zurückgesetzte Einheit mit vergrößerter nutzbarer Werkzeuglänge und Innenkühlung als Option.

Rear offset unit with increased usable tool length and internal coolant is an option.

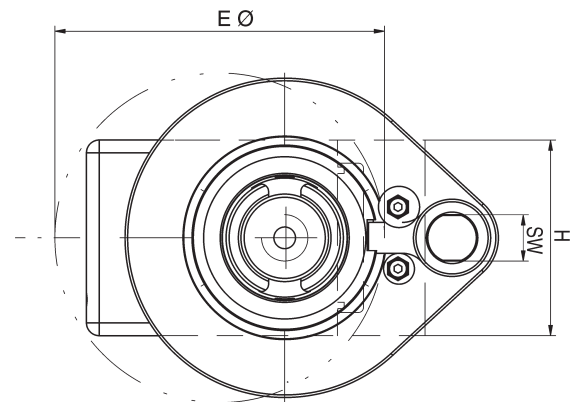
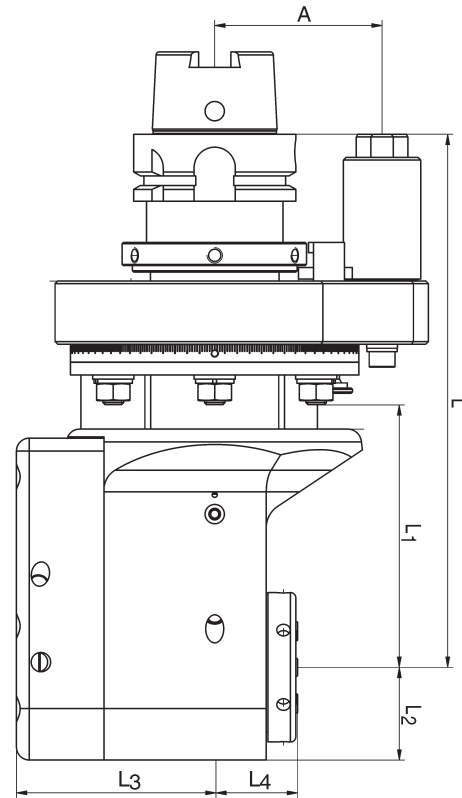
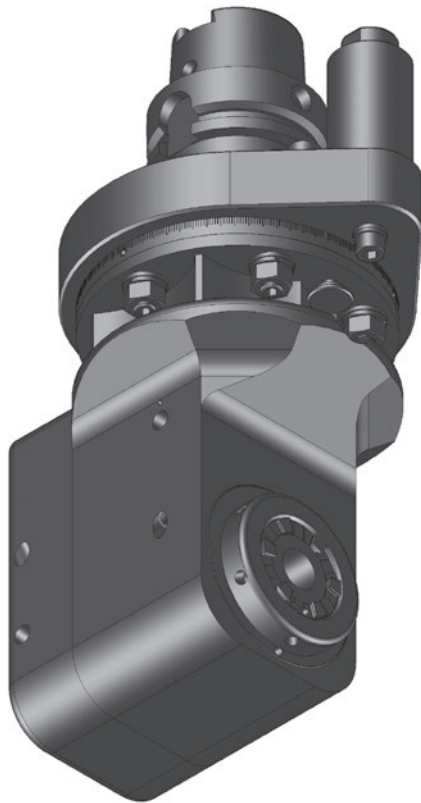

Baugröße Size	Bestell-Nr. / Order No.			Werkzeug Aufnahme Toolholder	Eintauch / Clearance Ø E mm		L3 mm		L4 mm	
	ohne / without	extern / external	intern / internal							
5	135405	162860	167996	ER 25	103	103	57,0	57,0	35,8	41,6
5	105459	162884	162885	mi 40	130	130	57,0	57,0	50,3	50,3
7	135416	174283	135398	ER 32	128	128	77,5	77,5	34,0	38,0
7	173528	162899	167022	mi 50	150	150	77,5	77,5	55,0	55,0

Baugröße Size	max. Drehmoment Torque max.	max. Drehzahl (U/min.) Rev. max. (RPM)	Übersetzung Gear Ratio	L mm	L1 mm	L2 mm	H mm	A mm	kg	SW
5	30 Nm	8.000	i = 1:1	187	80	28,5	57	65	6,5	18
7	70 Nm	6.000	i = 1:1	205	100	38,0	76	65	8,5	18

HSK 63

ZWS

Winkelkopf 90° zurückversetzt schmale Bauform Angle Head 90°, Offset Slim Type

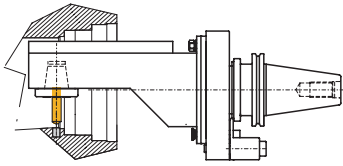

Zurückversetzte und schmale Bauform zum Eintauchen in kleine Bohrungen oder eingegengten Platzverhältnissen.

Offset narrow form to slide into small bores or when clearance issues / space restrictions are issue.



Achtung:
Drehrichtungsumkehr

Attention!
Reversal of rotation
direction

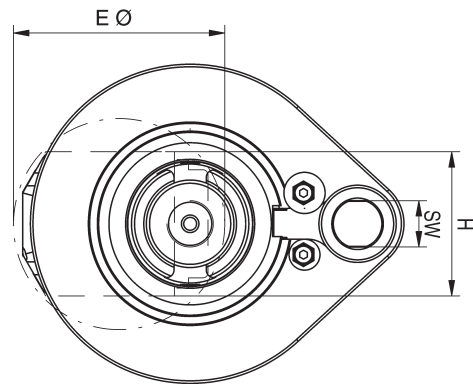
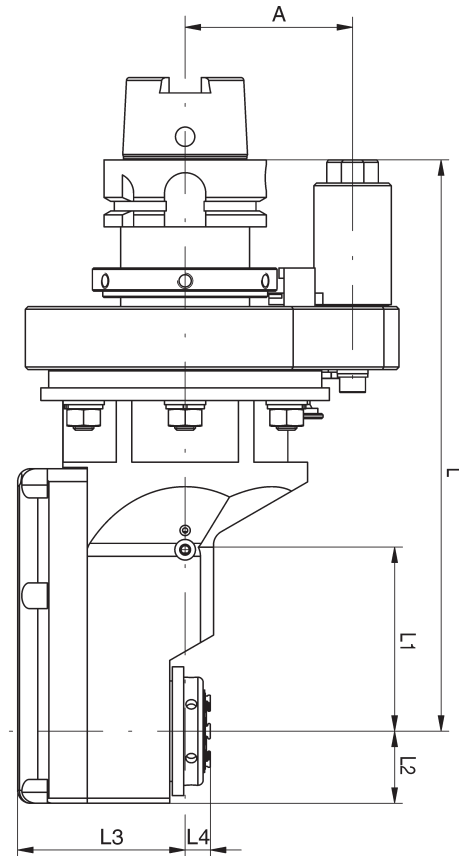
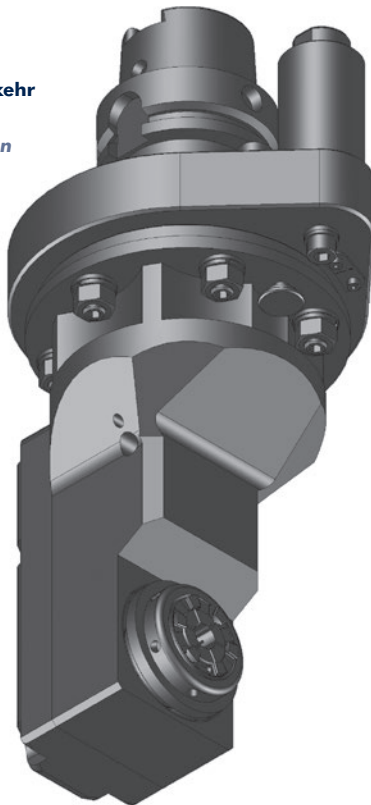

Baugröße Size	Bestell-Nr. / Order No.			Werkzeug Aufnahme Toolholder	Eintauch / Clearance Ø E mm		L3 mm		L4 mm	
	ohne / without	extern / external	intern / internal							
0	105670			ER 11	50		49,0		-8,0	
3	135633			ER 20	75		54,5		11,2	
3	105671			mi 32	100		54,5		26,0	
5	105674	162925		ER 25	82	82	65,0	65	10,0	10,0
5	105686	162937		mi 40	125	125	65,0	65	23,5	23,5

Baugröße Size	max. Drehmoment Torque max.	max. Drehzahl (U/min.) Rev. max. (RPM)	Übersetzung Gear Ratio	L mm	L1 mm	L2 mm	H mm	A mm	kg	SW
0	6 Nm	12.000	i = 1:1,67	220	38	20	36	65	7,0	18
3	15 Nm	10.000	i = 1:1	232	80	24	48	65	6,0	18
5	30 Nm	8.000	i = 1:1	222	76	28	56	65	6,5	18

HSK 63

WS



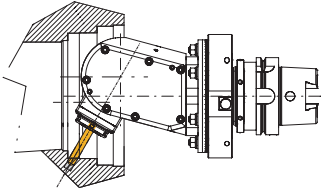

Winkelschwenkeinheit 0-98° Angle Head, Adjustable 0-98°

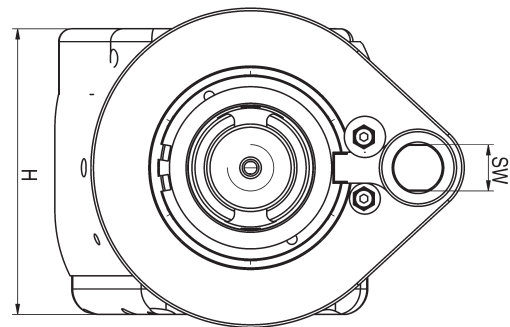
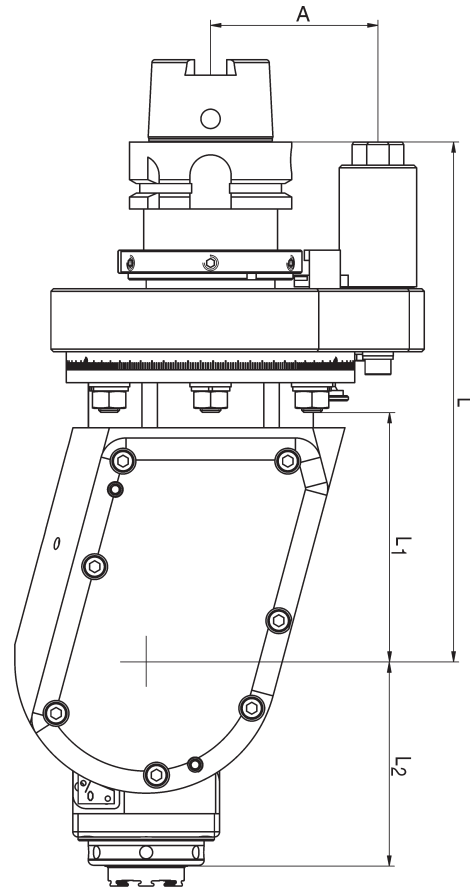
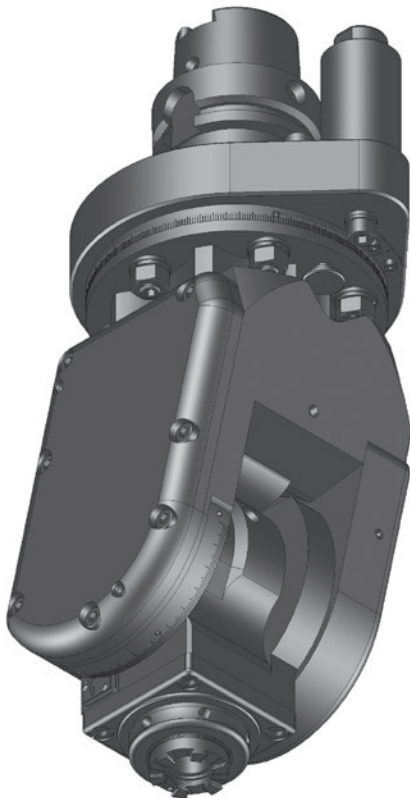

Einstellbare Winkelschwenkeinheit, um Bohr- und Fräsarbeiten in allen Winkeln durchführen zu können.

Adjustable angle unit to do boring and milling applications at any angle.



Baugröße Size	Bestell-Nr. / Order No. (i=1:1)		Bestell-Nr. / Order No. (i=1:2,25)		Werkzeug Aufnahme Toolholder	L2 mm	L4 mm
	 ohne / without	 intern / internal	 ohne / without	 intern / internal			
3	162945	105840	156558	156559	ER 20	75,0	20
3	156577	169142	156578	156579	mi 32	82,9	20
5	162961	135824	162962	135832	ER 25	84,0	25
5	162963	105853	162964	105858	mi 40	97,0	25

Baugröße Size	max. Drehmoment Torque max.	max. Drehzahl (U/min.) Rev. max. (RPM)	Übersetzung Gear Ratio	L mm	L1 mm	H mm	A mm	kg	SW
3	15 Nm	8.000 / 15.000	i = 1:1 / 1:2,25	196	91	96	65	8,0	18
5	30 Nm	7.000 / 13.500	i = 1:1 / 1:2,25	202	96	111	65	9,6	18

HSK 100

SW

Winkelkopf 90° Angle Head 90°

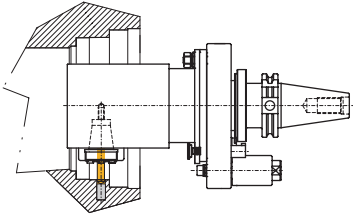

Für einzelne Bohr- und Fräsoptionen
ohne räumliche Beschränkungen.

For single boring and milling operations
without clearance issues.



Achtung:
Drehrichtungsumkehr

Attention!
Reversal of rotation
direction

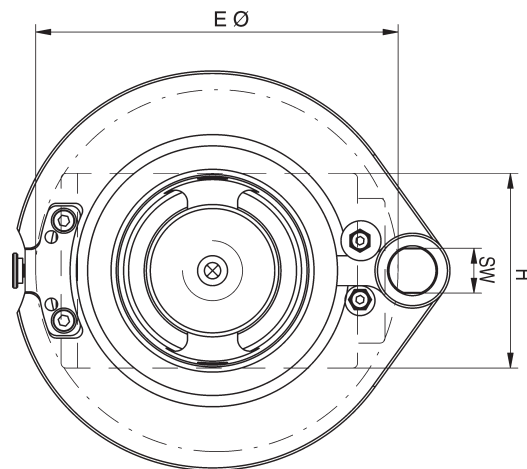
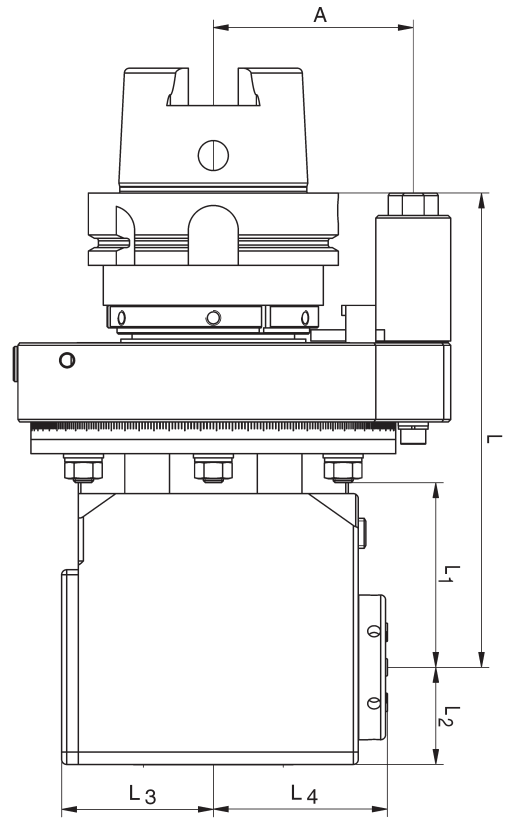
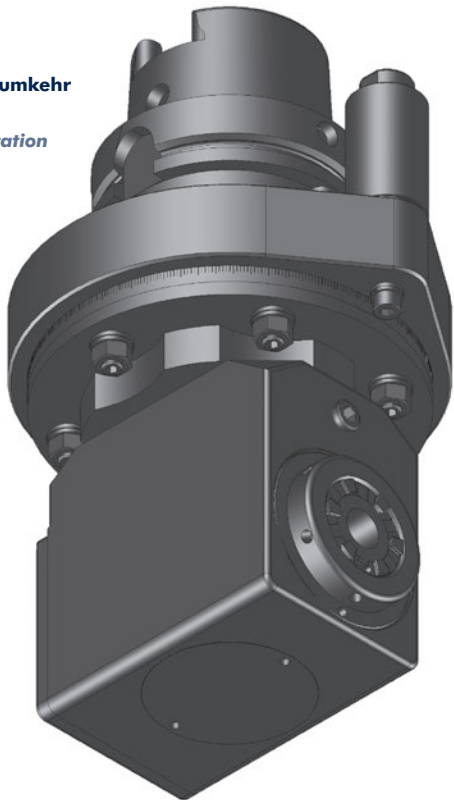

Baugröße Size	Bestell-Nr. / Order No.			Werkzeug Aufnahme Toolholder	Eintauch / Clearance Ø E mm		L3 mm		L4 mm	
	ohne / without	extern / external	intern / internal							
5	105499	162774	135462	ER 25	110	120	41,5	52	57,5	63,0
5	172644	162811	162812	mi 40	138	146	41,5	52	72,0	72,0
7	105515	169103	105506	ER 32	145	155	61,0	75	70,0	75,0
7	167699	176169	162798	mi 50	172	178	61,0	75	83,0	83,0
9	105557	169104	105544	ER 40	195	195	81,0	81	92,0	96,0
9	173506	162788	162789	mi 63	224	224	81,0	81	111,5	111,5

Baugröße Size	max. Drehmoment Torque max.	max. Drehzahl (U/min.) Rev. max. (RPM)	Übersetzung Gear Ratio	L mm	L1 mm	L2 mm	H mm	A mm	kg	SW
5	30 Nm	8.000	i = 1:1	190	75	34	68	80	10,5	18
7	70 Nm	6.500	i = 1:1	190	75	39	78	80	12,0	18
9	150 Nm	5.000	i = 1:1	225	109	52	104	80	18,0	18

HSK 100

DW

Doppel-Winkelkopf 90° Double Angle Head 90°

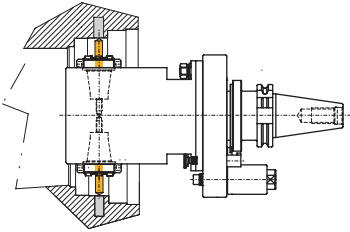

Doppelspindel um zwei entgegengesetzte Bohr- und Fräsoperationen durchführen zu können.

Double spindle unit to do two boring and milling operations in opposite directions.

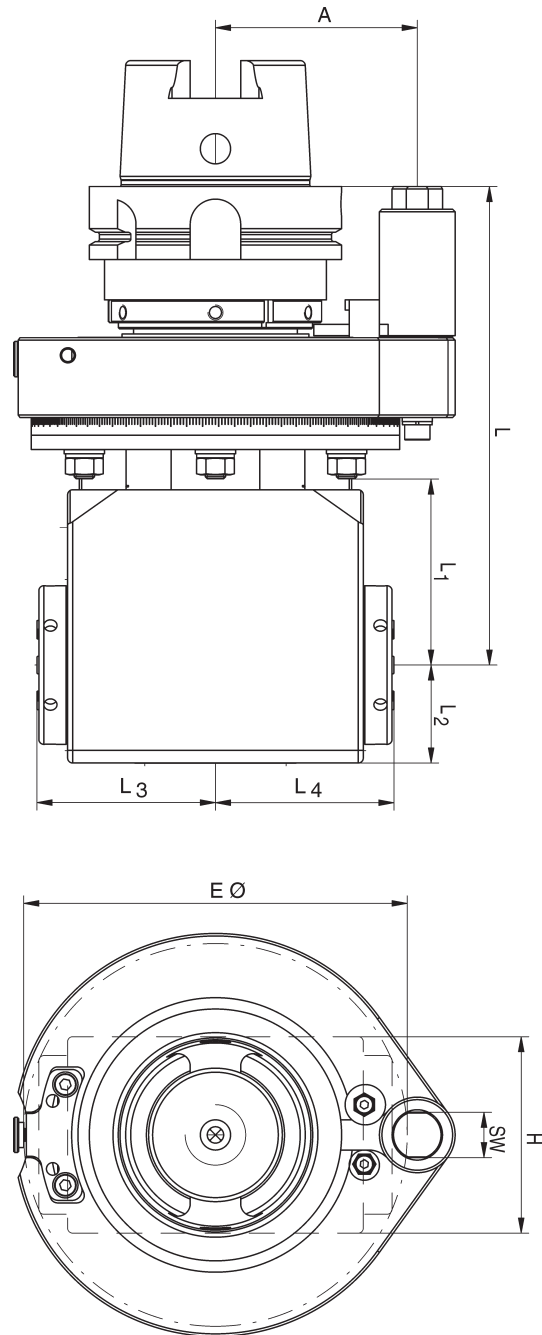
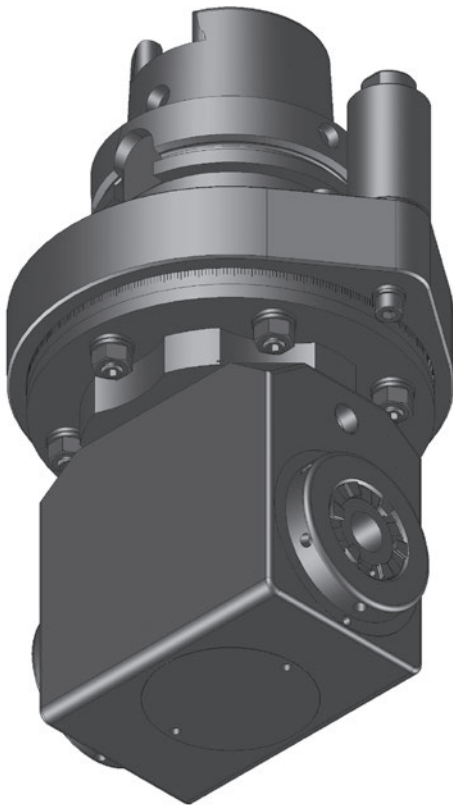

Baugröße Size	Bestell-Nr. / Order No.			Werkzeug Aufnahme Toolholder	Eintauch / Clearance Ø E mm		L3 mm		L4 mm	
	ohne / without	extern / external	intern / internal							
5	135711	162827		2 x ER 25	125	125	62,0	62,0	62,0	62,0
5	173514	162845		2 x mi 32	200	200	76,5	76,5	76,5	76,5
7	135749	162833		2 x ER 32	152	152	71,2	71,2	71,2	71,2
7	167700	162850		2 x mi 40	220	220	88,0	88,0	88,0	88,0
9	105790	162837		2 x ER 40	210	210	103,0	103,0	103,0	103,0
9	167705	162854		2 x mi 50	250	250	116,0	116,0	116,0	116,0

Baugröße Size	max. Drehmoment Torque max.	max. Drehzahl (U/min.) Rev. max. (RPM)	Übersetzung Gear Ratio	L mm	L1 mm	L2 mm	H mm	A mm	kg	SW
5	30 Nm	8.000	i = 1:1	190	70	34	68	80	11,5	18
7	70 Nm	6.500	i = 1:1	190	70	39	78	80	13,5	18
9	150 Nm	4.000	i = 1:1	225	109	58	108	80	20,0	18

HSK 100

ZW

Winkelkopf 90° zurückversetzt Angle Head 90°, Offset Type

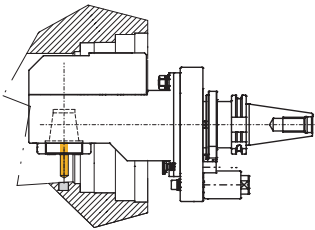

Zurückgesetzte Einheit mit vergrößerter nutzbarer Werkzeuglänge und Innenkühlung als Option.

Rear offset unit with increased usable tool length and internal coolant is an option.

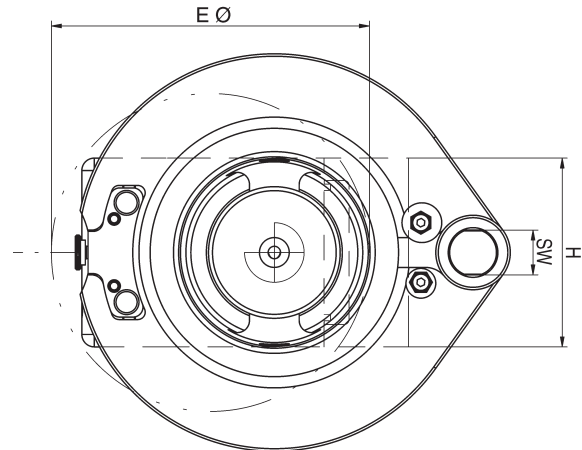
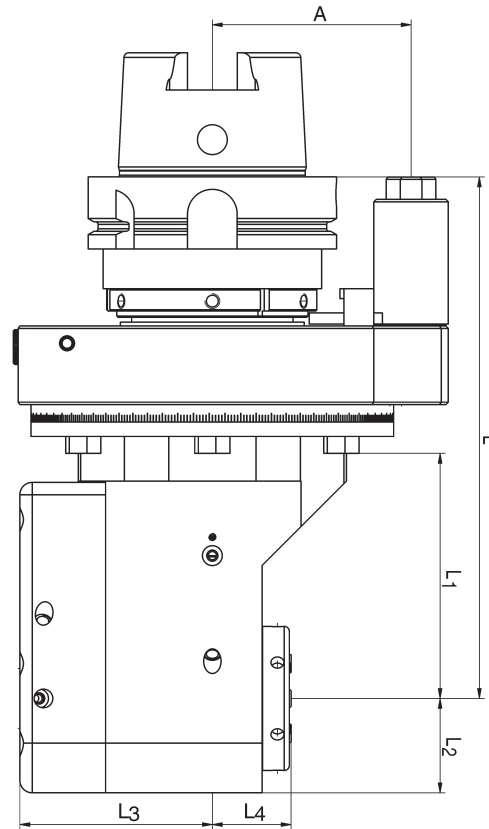
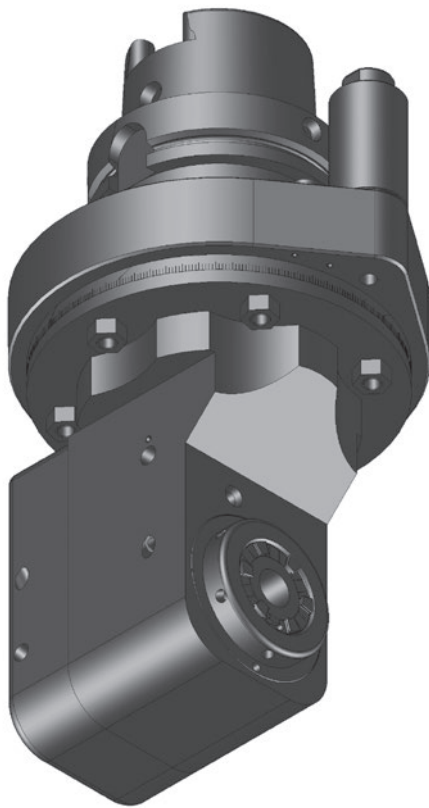

Baugröße Size	Bestell-Nr. / Order No.			Werkzeug Aufnahme Toolholder	Eintauch / Clearance Ø E mm		L3 mm		L4 mm	
	ohne / without	extern / external	intern / internal							
5	105466	162867	168564	ER 25	103	103	58,0	58,0	35,8	41,6
5	173522	162892	162893	mi 40	133	133	58,0	58,0	50,3	50,3
7	105431	162873	166868	ER 32	128	128	77,5	77,5	32,2	38,0
7	173529	162903	105469	mi 50	152	152	77,5	77,5	55,0	55,0
9	135375	105471	135399	ER 40	140	140	89,0	89,0	31,0	34,8
9	173534	162910	168369	mi 63	165	165	89,0	89,0	48,3	48,3

Baugröße Size	max. Drehmoment Torque max.	max. Drehzahl (U/min.) Rev. max. (RPM)	Übersetzung Gear Ratio	L mm	L1 mm	L2 mm	H mm	A mm	kg	SW
5	30 Nm	8.000	i = 1:1	195	79	28,5	57	80	11,5	18
7	70 Nm	6.500	i = 1:1	210	94	38,0	76	80	14,0	18
9	150 Nm	5.000	i = 1:1	270	152	52,0	104	80	19,0	18

HSK 100

ZWS

Winkelkopf 90° zurückversetzt schmale Bauform Angle Head 90°, Offset Slim Type

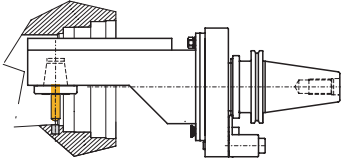

Zurückversetzte und schmale Bauform zum Eintauchen in kleine Bohrungen oder eingegengten Platzverhältnissen.

Offset narrow form to slide into small bores or when clearance issues / space restrictions are issue.



Achtung:
Drehrichtungsumkehr

Attention!
Reversal of rotation
direction

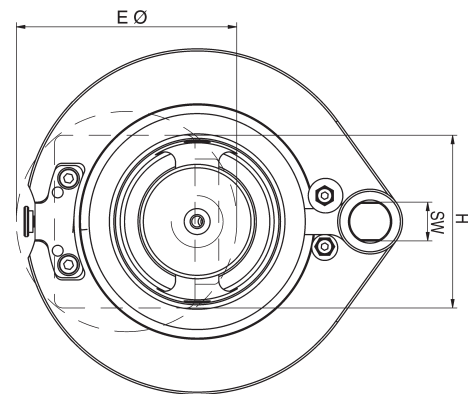
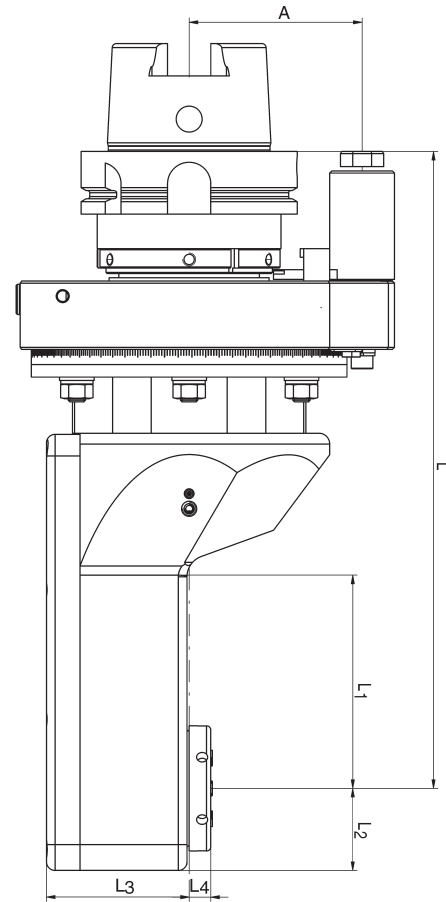
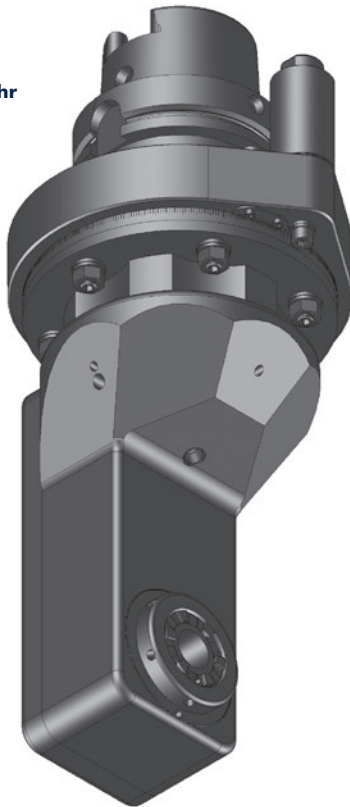

Baugröße Size	Bestell-Nr. / Order No.			Werkzeug Aufnahme Toolholder	Eintauch / Clearance Ø E mm		L3 mm		L4 mm	
	ohne / without	extern / external	intern / internal							
0	135592			ER 11	50		49		-8,0	
5	135651	105683		ER 25	82	82	65	65	10,0	10,0
5	173542	162941		mi 40	125	125	65	65	23,5	23,5
7	135656	162928		ER 32	102	102	66	66	13,0	13,0
7	105687	169062		mi 50	135	135	66	66	29,0	29,0

Baugröße Size	max. Drehmoment Torque max.	max. Drehzahl (U/min.) Rev. max. (RPM)	Übersetzung Gear Ratio	L mm	L1 mm	L2 mm	H mm	A mm	kg	SW
0	6 Nm	12.000	i = 1:1,67	237,5	38	20	36	80	11,0	18
5	30 Nm	8.000	i = 1:1	225,0	76	28	56	80	12,5	18
7	70 Nm	6.500	i = 1:1	295,0	100	38	80	80	13,5	18

HSK 100

WS

Winkelschwenkeinheit 0-98° Angle Head, Adjustable 0-98°

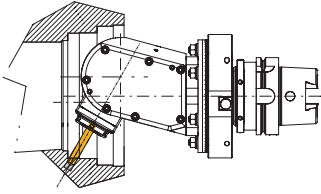

Einstellbare Winkelschwenkeinheit, um Bohr- und Fräsarbeiten in allen Winkeln durchführen zu können.

Adjustable angle unit to do boring and milling applications at any angle.

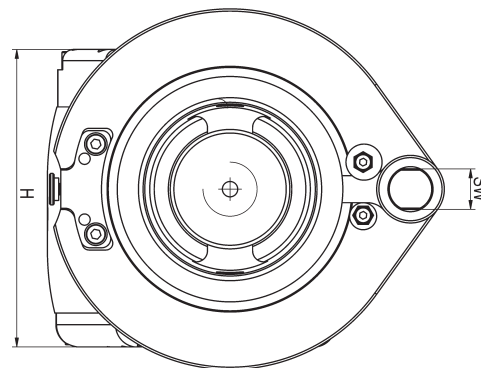
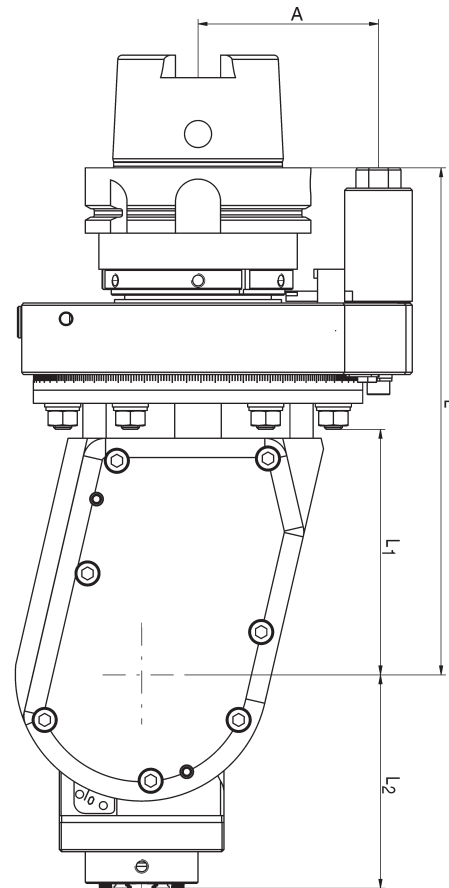
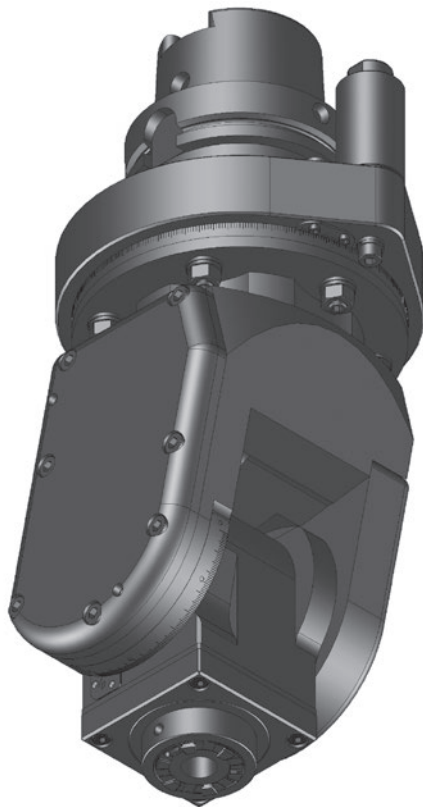

Baugröße Size	Bestell-Nr. / Order No. (i=1:1)		Bestell-Nr. / Order No. (i=1:2,25)		Werkzeug Aufnahme Toolholder	L2 mm	L4 mm
	ohne / without	intern / internal	ohne / without	intern / internal			
5	162976	135865	162977	162978	ER 25	84	25
5	162979	169980	162980	162981	mi 40	97	25
7	162986	105866			ER 32	95	25
7	162991	169942			mi 50	108	25

Baugröße Size	max. Drehmoment Torque max.	max. Drehzahl (U/min.) Rev. max. (RPM)	Übersetzung Gear Ratio	L mm	L1 mm	H mm	A mm	kg	SW
5	30 Nm	7.000 / 13.500	i = 1:1 / 1:2,25	205	96	111	80	14,0	18
7	70 Nm	6.000	i = 1:1	225	109	132	80	16,0	18

MAS-BT 40 SW

**Winkelkopf 90°
Angle Head 90°**

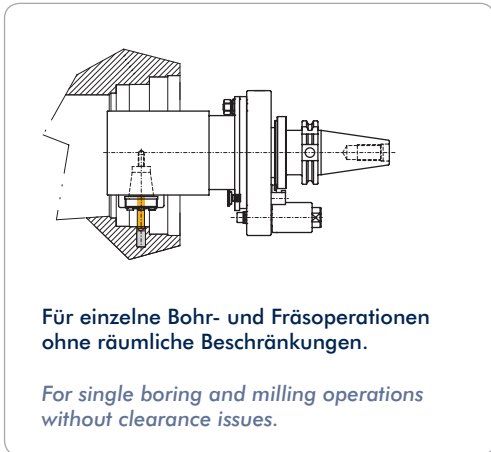

**Achtung:
Drehrichtungsumkehr**

**Attention!
Reversal of rotation
direction**

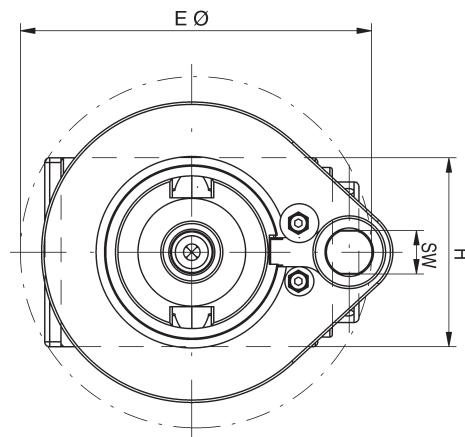
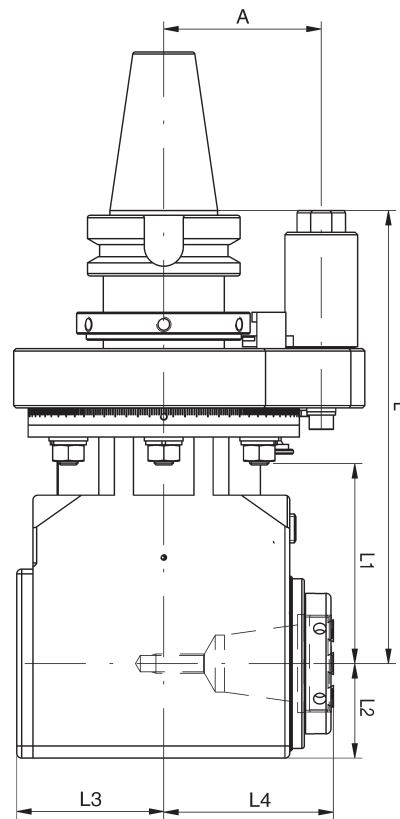
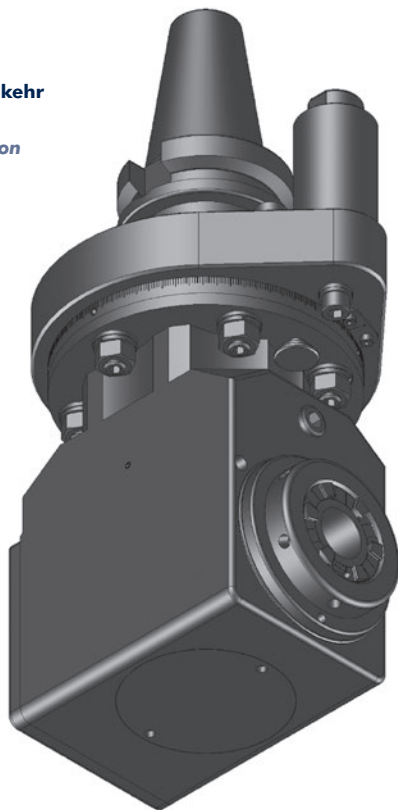

Baugröße Size	Bestell-Nr. / Order No.			Werkzeug Aufnahme Toolholder	Eintauch / Clearance Ø E mm		L3 mm		L4 mm	
	ohne / without	extern / external	intern / internal							
1	135431	135444	135451	ER 16	91	96	29,0	44	45,0	50
5	135459	105503	135435	ER 25	110	120	41,5	52	57,5	63
5	173000	162802	162803	mi 40	138	146	41,5	52	72,0	72
7	135470	162777	105505	ER 32	145	155	61,0	75	70,0	75
7	170653	176278	167889	mi 50	172	178	61,0	75	83,0	83

Baugröße Size	max. Drehmoment Torque max.	max. Drehzahl (U/min.) Rev. max. (RPM)	Übersetzung Gear Ratio	L mm	L1 mm	L2 mm	H mm	A mm	kg	SW
1	12 Nm	10.000	i = 1:1	187	80	22	44	65	6,0	18
5	30 Nm	8.000	i = 1:1	187	80	34	68	65	6,5	18
7	70 Nm	6.500	i = 1:1	187	80	39	78	65	8,0	18

MAS-BT 40

DW

Doppel-Winkelkopf 90° Double Angle Head 90°

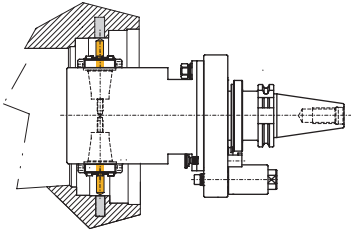

Doppelspindler um zwei entgegengesetzte Bohr- und Fräsoperationen durchführen zu können.

Double spindle unit to do two boring and milling operations in opposite directions.

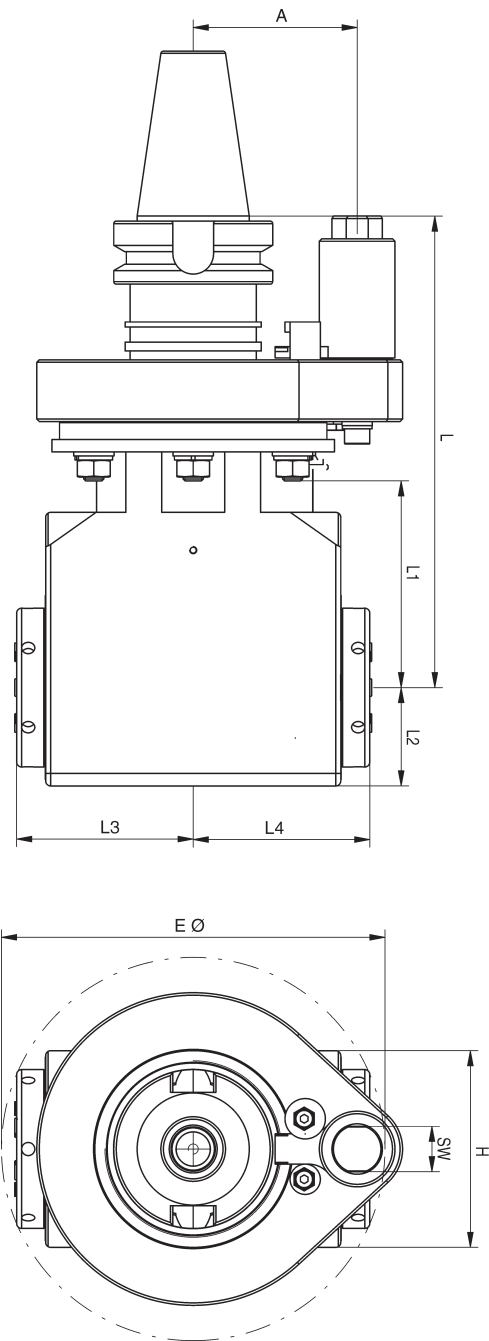
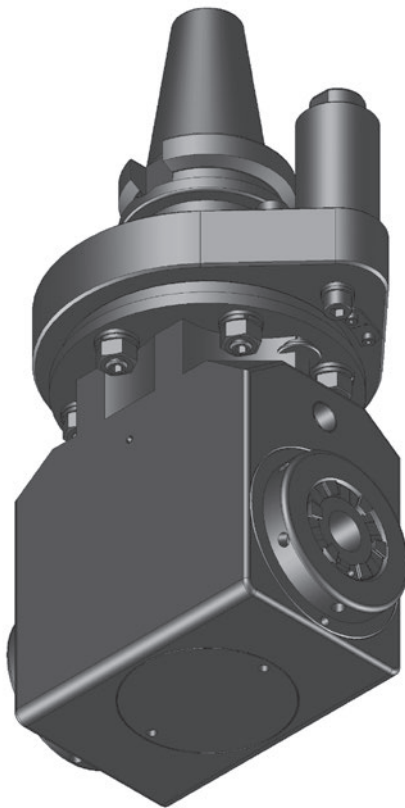

Baugröße Size	Bestell-Nr. / Order No.			Werkzeug Aufnahme Toolholder	Eintauch / Clearance Ø E mm		L3 mm		L4 mm	
	ohne / without	extern / external	intern / internal							
5	135717	162823		2 x ER 25	125	125	62,0	62,0	62,0	62,0
5	173509	162840		2 x mi 32	200	200	76,5	76,5	76,5	76,5
7	135729	162829		2 x ER 32	152	152	71,2	71,2	71,2	71,2
7	173516	162847		2 x mi 40	220	220	88,0	88,0	88,0	88,0

Baugröße Size	max. Drehmoment Torque max.	max. Drehzahl (U/min.) Rev. max. (RPM)	Übersetzung Gear Ratio	L mm	L1 mm	L2 mm	H mm	A mm	kg	SW
5	30 Nm	8.000	i = 1:1	187	80	39	78	65	7,5	18
7	70 Nm	6.500	i = 1:1	187	80	39	78	65	8,5	18

MAS-BT 40 ZW

Winkelkopf 90° zurückversetzt
Angle Head 90°, Offset Type

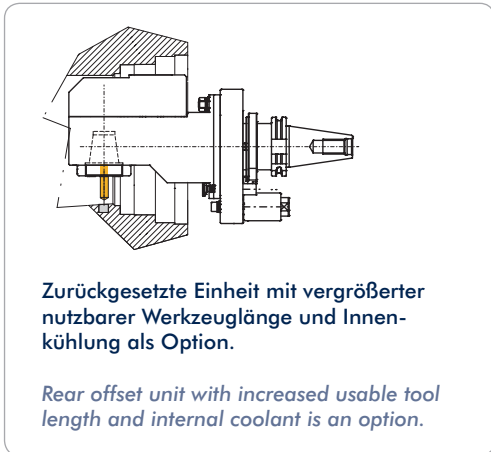

Zurückgesetzte Einheit mit vergrößerter nutzbarer Werkzeuglänge und Innenkühlung als Option.

Rear offset unit with increased usable tool length and internal coolant is an option.

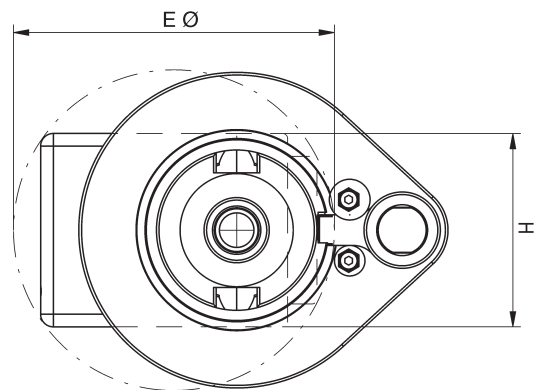
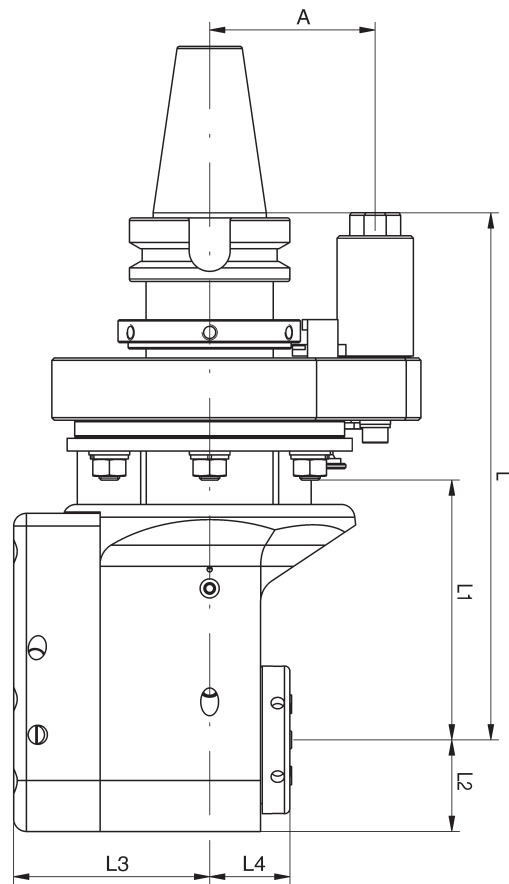
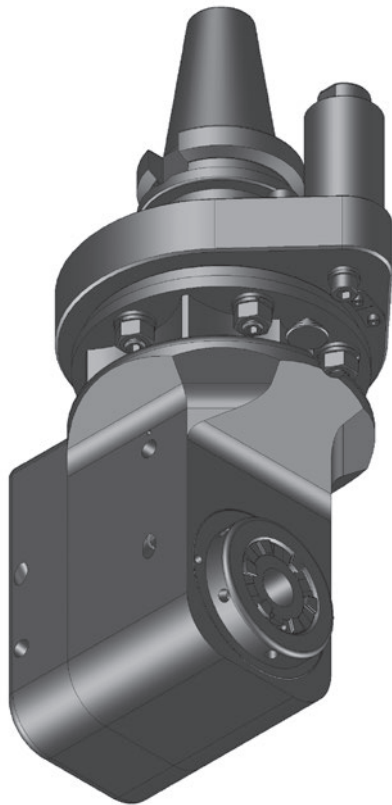

Baugröße Size	Bestell-Nr. / Order No.			Werkzeug Aufnahme Toolholder	Eintauch / Clearance Ø E mm		L3 mm		L4 mm	
	ohne / without	extern / external	intern / internal							
5	105435	162857	162859	ER 25	103	103	57,0	57,0	35,8	41,6
5	105458	162882	162883	mi 40	130	130	57,0	57,0	50,3	50,3
7	105477	162870	172498	ER 32	128	128	77,5	77,5	32,2	38,0
7	173527	162897	162898	mi 50	150	150	77,5	77,5	55,0	55,0

Baugröße Size	max. Drehmoment Torque max.	max. Drehzahl (U/min.) Rev. max. (RPM)	Übersetzung Gear Ratio	L mm	L1 mm	L2 mm	H mm	A mm	kg	SW
5	30 Nm	8.000	i = 1:1	187	80	28,5	57	65	6,5	18
7	70 Nm	6.000	i = 1:1	205	100	38,0	76	65	8,5	18

MAS-BT 40 ZWS

Winkelkopf 90° zurückversetzt schmale Bauform
Angle Head 90°, Offset Slim Type

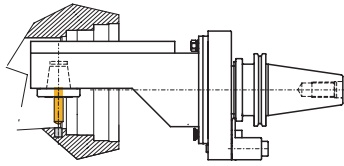

Zurückversetzte und schmale Bauform zum Eintauchen in kleine Bohrungen oder eingegengten Platzverhältnissen.

Offset narrow form to slide into small bores or when clearance issues / space restrictions are issue.



Achtung:
Drehrichtungsumkehr

Attention!
Reversal of rotation direction

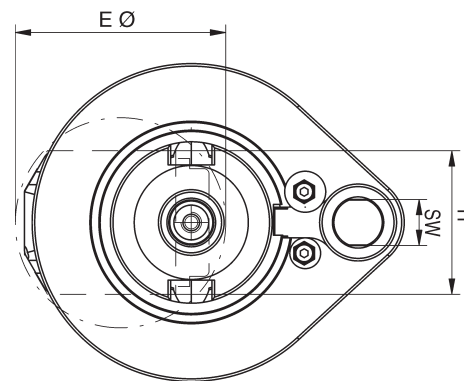
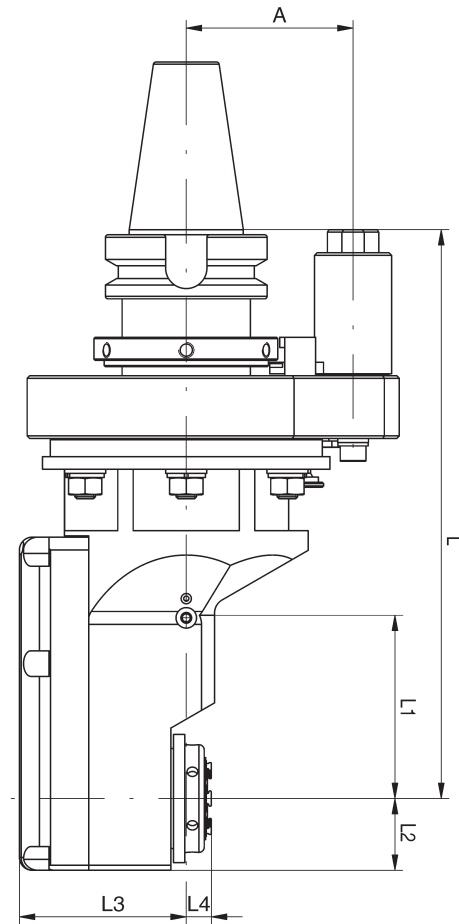
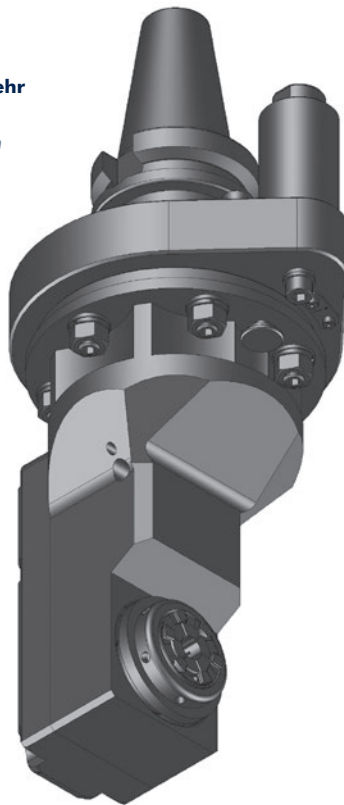

Baugröße Size	Bestell-Nr. / Order No.			Werkzeug Aufnahme Toolholder	Eintauch / Clearance Ø E mm		L3 mm		L4 mm	
	ohne / without	extern / external	intern / internal							
0	105651			ER 11	50		49,0		-8,0	
3	135629			ER 20	75		54,5		11,2	
3	173536			mi 32	100		54,5		26,0	
5	135649	162924		ER 25	82	82	65,0	65,0	10,0	10,0
5	173537	162936		mi 40	125	125	65,0	65,0	23,5	23,5

Baugröße Size	max. Drehmoment Torque max.	max. Drehzahl (U/min.) Rev. max. (RPM)	Übersetzung Gear Ratio	L mm	L1 mm	L2 mm	H mm	A mm	kg	SW
0	6 Nm	12.000	i = 1:1,67	220	38	20	36	65	7,0	18
3	15 Nm	10.000	i = 1:1	232	80	24	48	65	6,0	18
5	30 Nm	8.000	i = 1:1	222	76	28	56	65	6,5	18

MAS-BT 40

WS

Winkelschwenkeinheit 0-98° Angle Head, Adjustable 0-98°

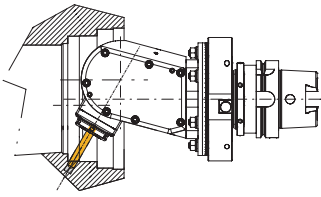

Einstellbare Winkelschwenkeinheit, um Bohr- und Fräsarbeiten in allen Winkeln durchführen zu können.

Adjustable angle unit to do boring and milling applications at any angle.

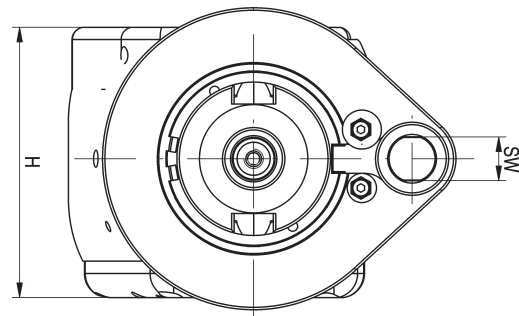
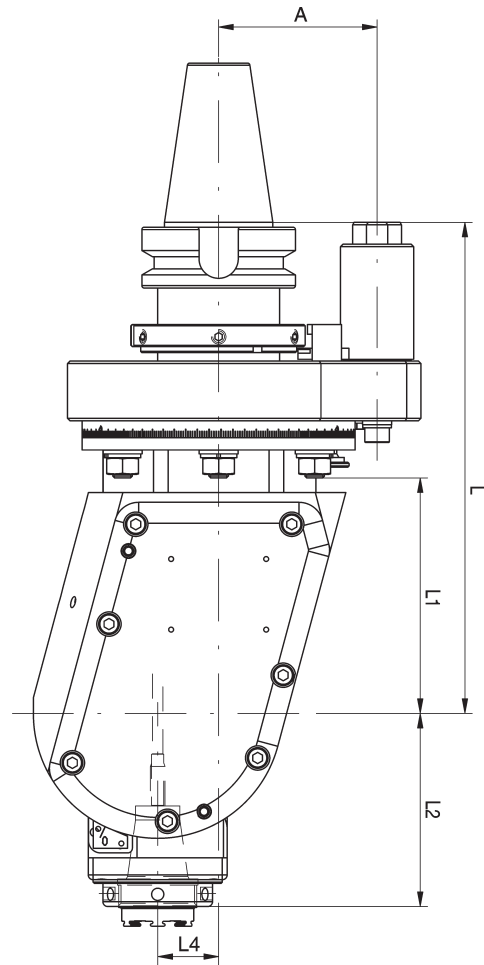
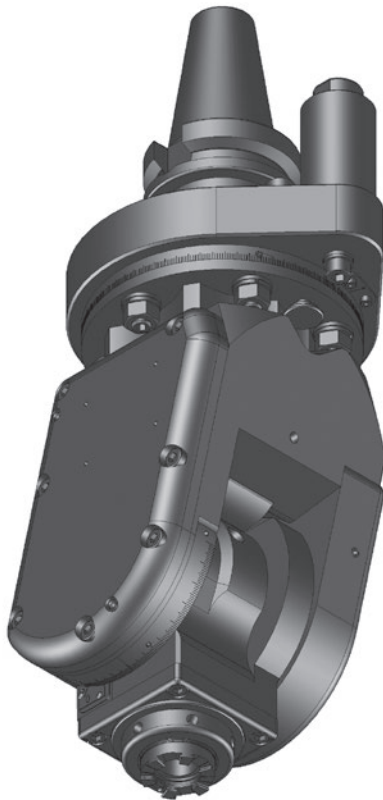

Baugröße Size	Bestell-Nr. / Order No. (i=1:1)		Bestell-Nr. / Order No. (i=1:2,25)		Werkzeug Aufnahme Toolholder	L2 mm	L4 mm
	ohne / without	intern / internal	ohne / without	intern / internal			
3	173907	105808	162858	162933	ER 20	75,0	20
3	156569	167418	156570	156574	mi 32	82,9	20
5	162955	135813	162957	162956	ER 25	84,0	25
5	162958	169976	162959	162960	mi 40	97,0	25

Baugröße Size	max. Drehmoment Torque max.	max. Drehzahl (U/min.) Rev. max. (RPM)	Übersetzung Gear Ratio	L mm	L1 mm	H mm	A mm	kg	SW
3	15 Nm	8.000 / 15.000	i = 1:1 / 1:2,25	196	100	96	65	8,0	18
5	30 Nm	7.000 / 13.500	i = 1:1 / 1:2,25	202	100	111	65	9,6	18

MAS-BT 50 SW

**Winkelkopf 90°
Angle Head 90°**



Für einzelne Bohr- und Fräsoperationen ohne räumliche Beschränkungen.

For single boring and milling operations without clearance issues.



Achtung:
Drehrichtungsumkehr

Attention!
Reversal of rotation direction

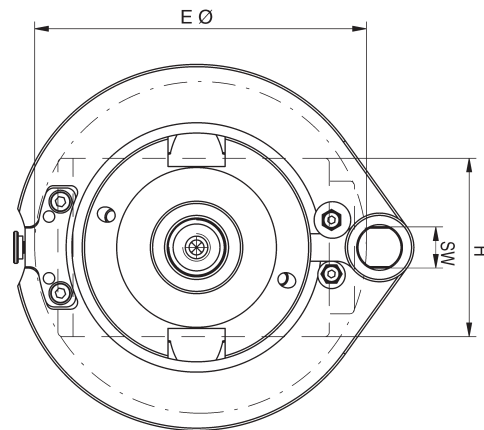
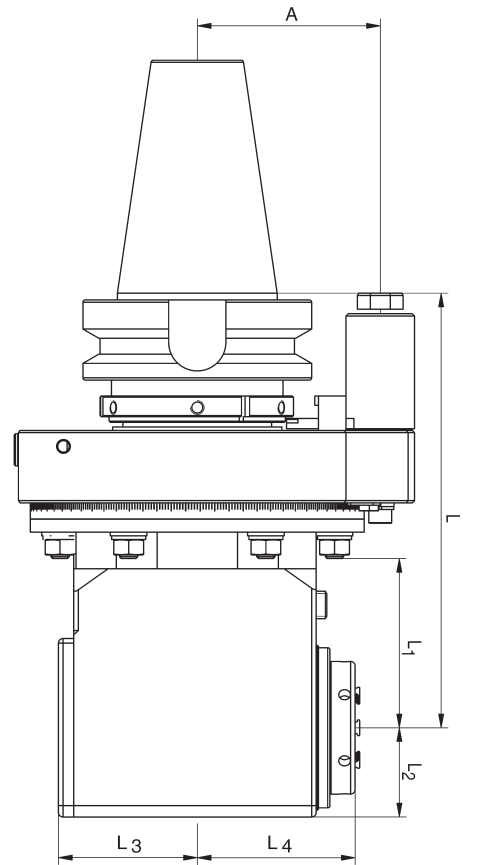
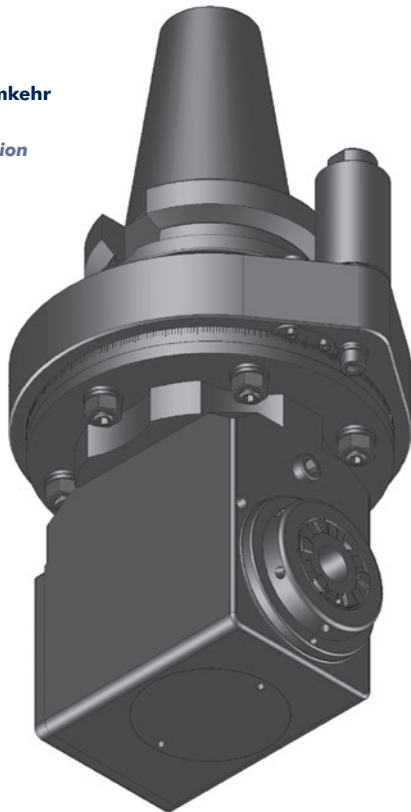

Baugröße Size	Bestell-Nr. / Order No.			Werkzeug Aufnahme Toolholder	Eintauch / Clearance Ø E mm		L3 mm		L4 mm	
	ohne / without	extern / external	intern / internal							
5	105494	162772	162773	ER 25	110	120	41,5	52	57,5	63,0
5	173014	162809	162810	mi 40	138	146	41,5	52	72,0	72,0
7	135482	105538	172558	ER 32	145	155	61,0	75	70,0	75,0
7	105520	105508	174169	mi 50	172	178	61,0	75	83,0	83,0
9	105512	162783	167210	ER 40	195	195	81,0	81	92,0	96,0
9	167208	162787	167211	mi 63	224	224	81,0	81	111,5	111,5

Baugröße Size	max. Drehmoment Torque max.	max. Drehzahl (U/min.) Rev. max. (RPM)	Übersetzung Gear Ratio	L mm	L1 mm	L2 mm	H mm	A mm	kg	SW
5	30 Nm	8.000	i = 1:1	190	75	34	68	80	10,5	18
7	70 Nm	6.500	i = 1:1	190	75	39	78	80	12,0	18
9	150 Nm	5.000	i = 1:1	225	109	52	104	80	18,0	18

MAS-BT 50 DW

**Doppel-Winkelkopf 90°
Double Angle Head 90°**

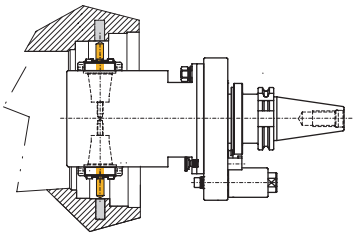

Doppelspindel um zwei entgegengesetzte Bohr- und Fräsoperationen durchführen zu können.

Double spindle unit to do two boring and milling operations in opposite directions.

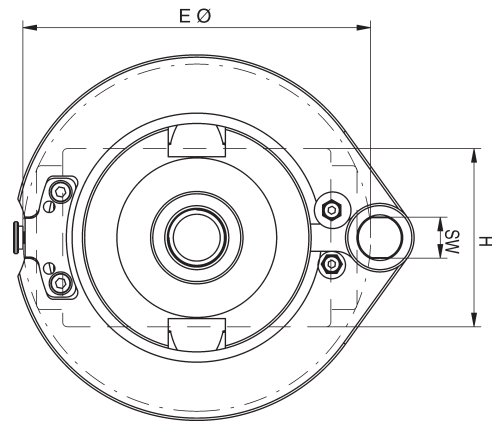
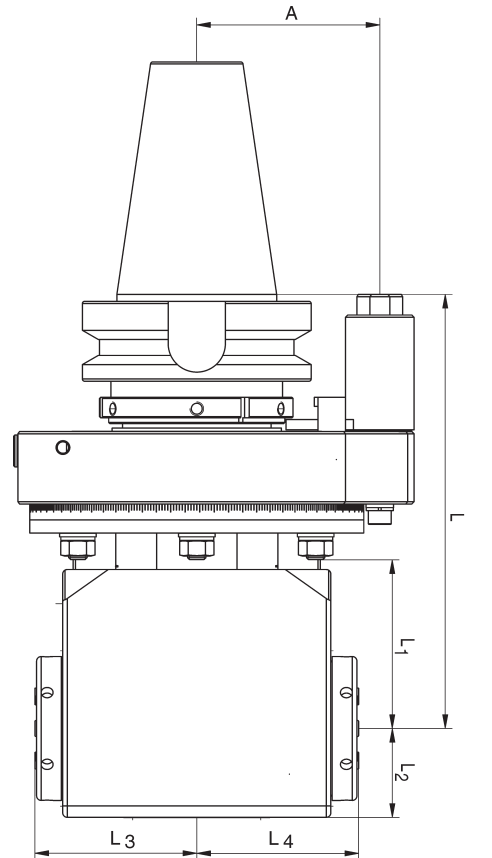
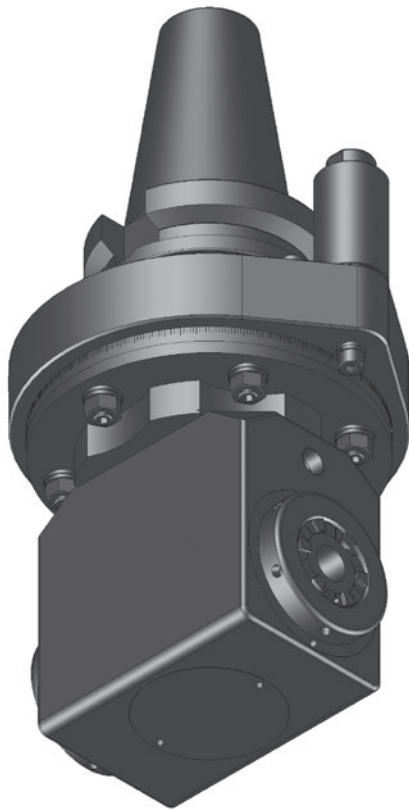

Baugröße Size	Bestell-Nr. / Order No.			Werkzeug Aufnahme Toolholder	Eintauch / Clearance Ø E mm		L3 mm		L4 mm	
	ohne / without	extern / external	intern / internal							
5	135691	162826		2 x ER 25	125	125	62,0	62,0	62,0	62,0
5	173513	162844		2 x mi 32	200	200	76,5	76,5	76,5	76,5
7	135724	162832		2 x ER 32	152	152	71,2	71,2	71,2	71,2
7	173518	162849		2 x mi 40	220	220	88,0	88,0	88,0	88,0
9	105788	162836		2 x ER 40	210	210	103,0	103,0	103,0	103,0
9	173520	162853		2 x mi 50	250	250	116,0	116,0	116,0	116,0

Baugröße Size	max. Drehmoment Torque max.	max. Drehzahl (U/min.) Rev. max. (RPM)	Übersetzung Gear Ratio	L mm	L1 mm	L2 mm	H mm	A mm	kg	SW
5	30 Nm	8.000	i = 1:1	190	70	34	68	80	11,5	18
7	70 Nm	6.500	i = 1:1	190	70	39	78	80	13,5	18
9	150 Nm	4.000	i = 1:1	225	109	58	108	80	20,0	18

MAS-BT 50

ZW

Winkelkopf 90° zurückversetzt Angle Head 90°, Offset Type

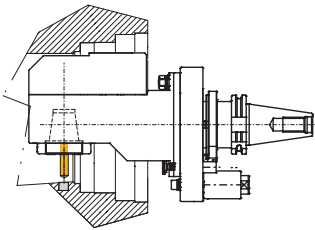

Zurückgesetzte Einheit mit vergrößerter nutzbarer Werkzeuglänge und Innenkühlung als Option.

Rear offset unit with increased usable tool length and internal coolant is an option.

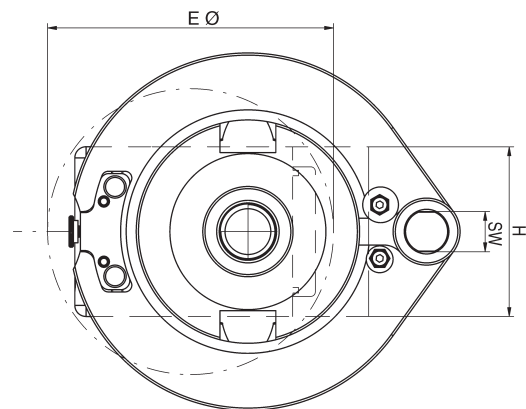
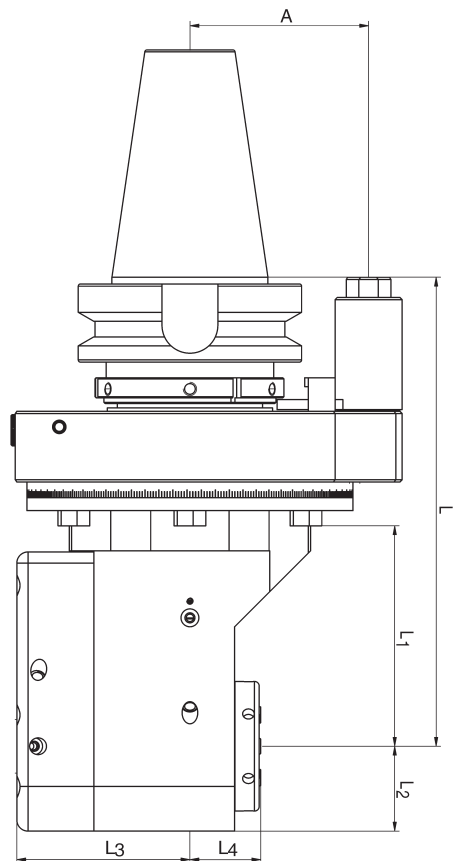
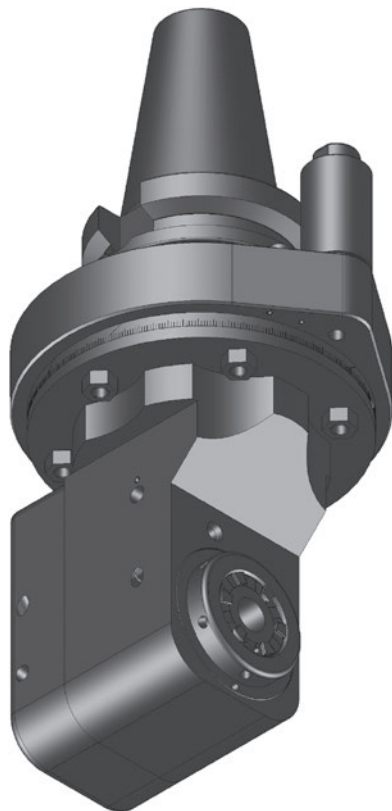

Baugröße Size	Bestell-Nr. / Order No.			Werkzeug Aufnahme Toolholder	Eintauch / Clearance Ø E mm		L3 mm		L4 mm	
	ohne / without	extern / external	intern / internal							
5	105417	162865	162866	ER 25	103	103	57,0	57,0	35,8	41,6
5	173525	162891	171760	mi 40	133	133	57,0	57,0	50,3	50,3
7	105460	162944	174661	ER 32	128	128	77,5	77,5	32,2	38,0
7	173531	162902	135378	mi 50	152	152	77,5	77,5	55,0	55,0
9	105470	168456	162878	ER 40	140	140	89,0	89,0	31,0	34,8
9	173533	162908	162909	mi 63	165	165	89,0	89,0	48,3	48,3

Baugröße Size	max. Drehmoment Torque max.	max. Drehzahl (U/min.) Rev. max. (RPM)	Übersetzung Gear Ratio	L mm	L1 mm	L2 mm	H mm	A mm	kg	SW
5	30 Nm	8.000	i = 1:1	195	79	28,5	57	80	11,5	18
7	70 Nm	6.000	i = 1:1	210	94	38,0	76	80	14,0	18
9	150 Nm	5.000	i = 1:1	270	110	52,0	104	80	19,0	18

MAS-BT 50 ZWS

Winkelkopf 90° zurückversetzt schmale Bauform
Angle Head 90°, Offset Slim Type

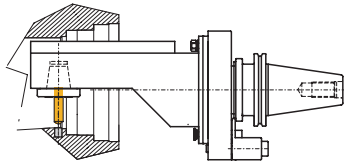

Zurückversetzte und schmale Bauform zum Eintauchen in kleine Bohrungen oder eingegengten Platzverhältnissen.

Offset narrow form to slide into small bores or when clearance issues / space restrictions are issue.



Achtung:
Drehrichtungsumkehr

Attention!
Reversal of rotation direction

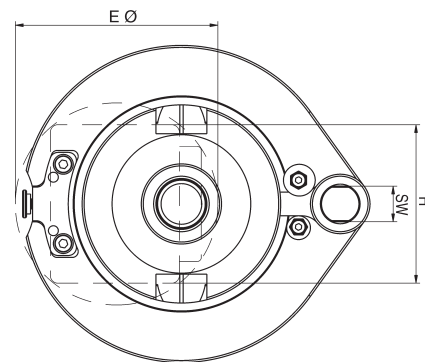
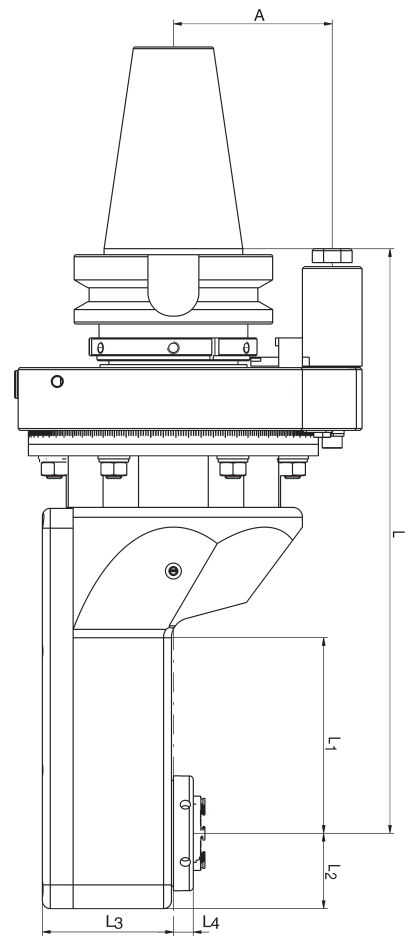
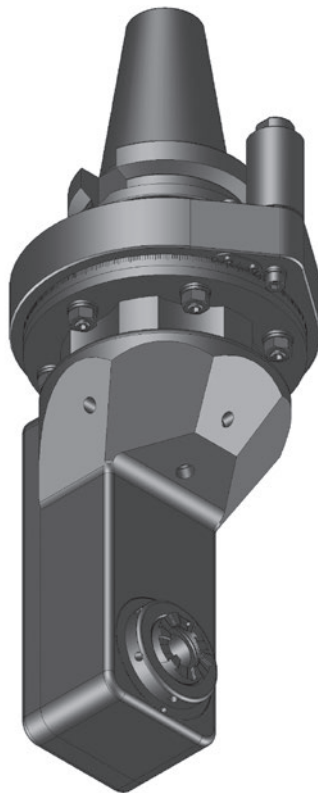

Baugröße Size	Bestell-Nr. / Order No.			Werkzeug Aufnahme Toolholder	Eintauch / Clearance Ø E mm		L3 mm		L4 mm	
	ohne / without	extern / external	intern / internal							
0	105652			ER 11	50		49		-8,0	
5	135650	168453		ER 25	82	82	65	65	10,0	10,0
5	173541	162940		mi 40	125	125	65	65	23,5	23,5
7	105698	168454		ER 32	102	102	66	66	13,0	13,0
7	173544	168460		mi 50	135	135	66	66	29,0	29,0

Baugröße Size	max. Drehmoment Torque max.	max. Drehzahl (U/min.) Rev. max. (RPM)	Übersetzung Gear Ratio	L mm	L1 mm	L2 mm	H mm	A mm	kg	SW
0	6 Nm	12.000	i = 1:1,67	237,5	38	20	36	80	11,0	18
5	30 Nm	8.000	i = 1:1	225,0	76	28	56	80	12,5	18
7	70 Nm	6.000	i = 1:1	295,0	100	38	80	80	13,5	18

MAS-BT 50

WS



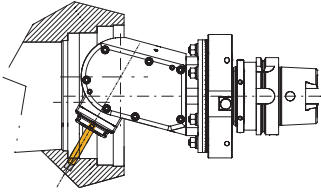

Winkelschwenkeinheit 0-98° Angle Head, Adjustable 0-98°

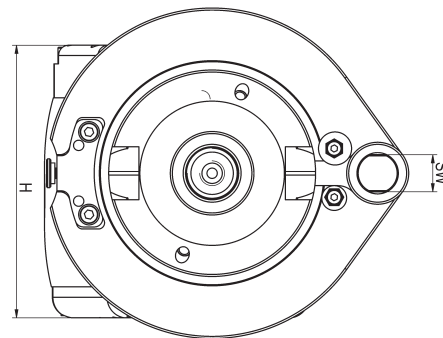
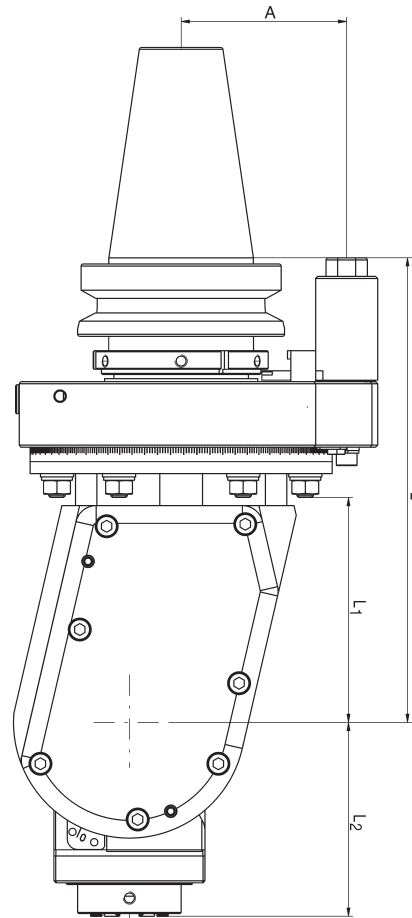
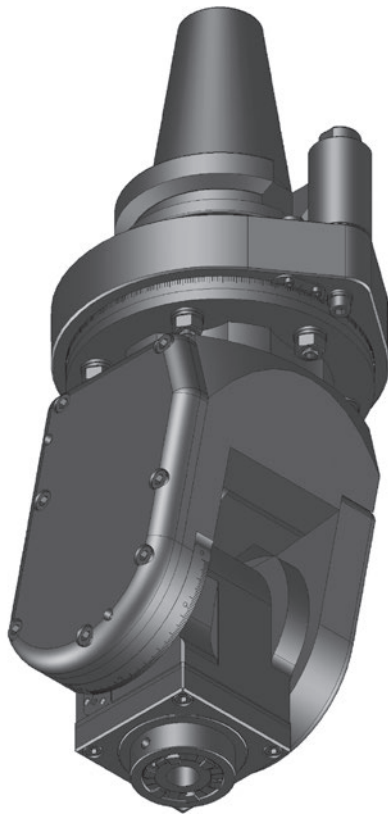

Einstellbare Winkelschwenkeinheit, um Bohr- und Fräsarbeiten in allen Winkeln durchführen zu können.

Adjustable angle unit to do boring and milling applications at any angle.



Baugröße Size	Bestell-Nr. / Order No. (i=1:1)		Bestell-Nr. / Order No. (i=1:2,25)		Werkzeug Aufnahme Toolholder	L2 mm	L4 mm
	 ohne / without	 intern / internal	 ohne / without	 intern / internal			
5	162970	105830	162972	162971	ER 25	84	25
5	162973	169979	162975	162974	mi 40	97	25
7	162985	105859			ER 32	95	25
7	162988	167553			mi 50	108	25

Baugröße Size	max. Drehmoment Torque max.	max. Drehzahl (U/min.) Rev. max. (RPM)	Übersetzung Gear Ratio	L mm	L1 mm	H mm	A mm	kg	SW
5	30 Nm	7.000 / 13.500	i = 1:1 / 1:2,25	205	100	111	80	14,0	18
7	70 Nm	6.000	i = 1:1	225	109	132	80	16,0	18

ANSI CAT 40 SW

**Winkelkopf 90°
Angle Head 90°**

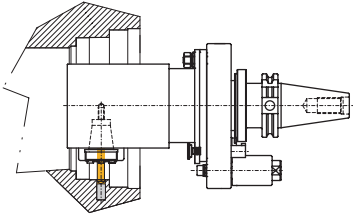

Für einzelne Bohr- und Fräsoperationen ohne räumliche Beschränkungen.

For single boring and milling operations without clearance issues.



**Achtung:
Drehrichtungsumkehr**

**Attention!
Reversal of rotation
direction**

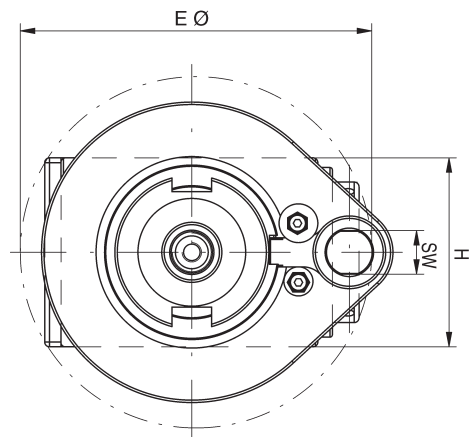
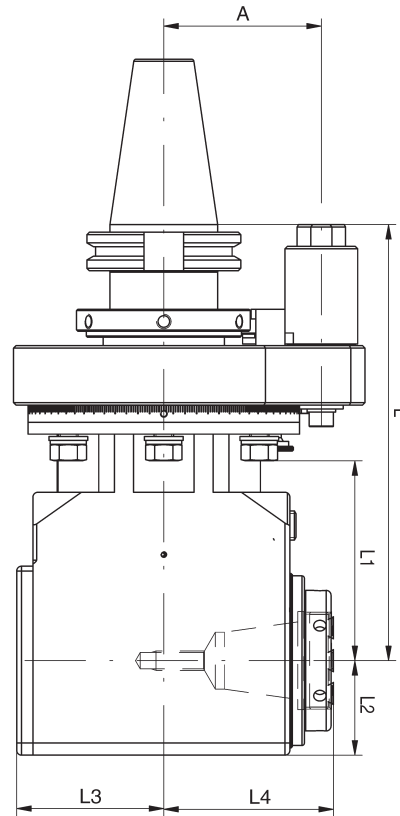
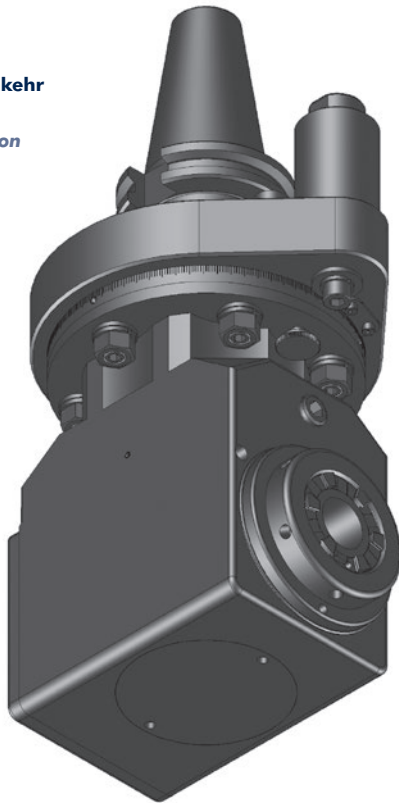

Baugröße Size	Bestell-Nr. / Order No.			Werkzeug Aufnahme Toolholder	Eintauch / Clearance Ø E mm		L3 mm		L4 mm	
	ohne / without	extern / external	intern / internal							
1	135465	162769	162776	ER 16	91	96	29,0	44	45,0	50
5	135432	183182	176443	ER 25	110	120	41,5	52	57,5	63
5	169839	173031	176540	mi 40	138	146	41,5	52	72,0	72
7	135477	162775	176444	ER 32	145	155	61,0	75	70,0	75
7	135485	105509	166537	mi 50	172	178	61,0	75	83,0	83

Baugröße Size	max. Drehmoment Torque max.	max. Drehzahl (U/min.) Rev. max. (RPM)	Übersetzung Gear Ratio	L mm	L1 mm	L2 mm	H mm	A mm	kg	SW
1	12 Nm	10.000	i = 1:1	180	80	22	44	65	6,0	18
5	30 Nm	8.000	i = 1:1	180	80	34	68	65	6,5	18
7	70 Nm	6.500	i = 1:1	180	80	39	78	65	8,0	18

ANSI CAT 40 DW

**Doppel-Winkelkopf 90°
Double Angle Head 90°**

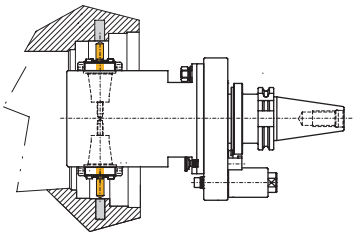

Doppelspindler um zwei entgegengesetzte Bohr- und Fräsoperationen durchführen zu können.

Double spindle unit to do two boring and milling operations in opposite directions.

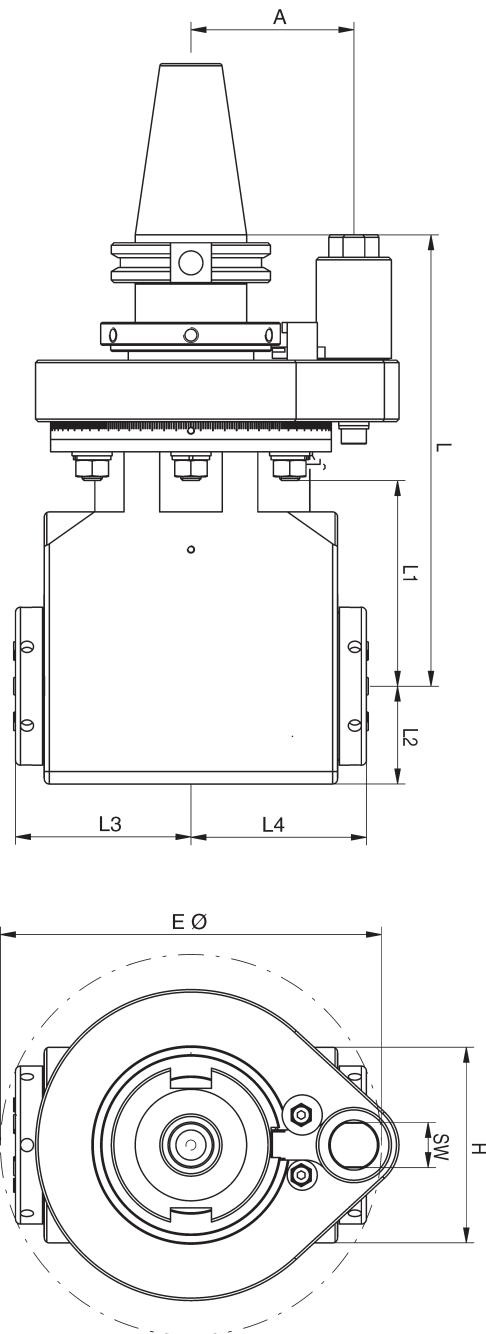
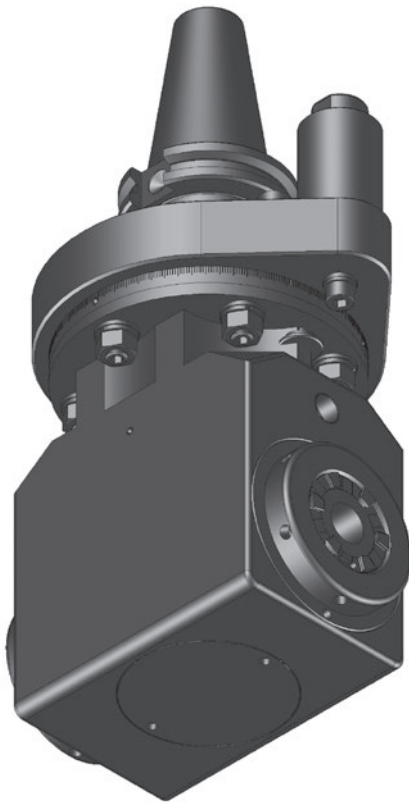

Baugröße Size	Bestell-Nr. / Order No.			Werkzeug Aufnahme Toolholder	Eintauch / Clearance Ø E mm		L3 mm		L4 mm	
	ohne / without	extern / external	intern / internal							
5	135696	162822		2 x ER 25	125	125	62,0	62,0	62,0	62,0
5	173508	162839		2 x mi 32	210	210	92,0	76,5	76,5	76,5
7	135720	162828		2 x ER 32	152	152	71,2	71,2	71,2	71,2
7	173515	162846		2 x mi 40	220	220	88,0	88,0	88,0	88,0

Baugröße Size	max. Drehmoment Torque max.	max. Drehzahl (U/min.) Rev. max. (RPM)	Übersetzung Gear Ratio	L mm	L1 mm	L2 mm	H mm	A mm	kg	SW
5	30 Nm	8.000	i = 1:1	180	80	39	78	65	7,5	18
7	70 Nm	6.500	i = 1:1	180	80	39	78	65	8,5	18

ANSI CAT 40 ZW

Winkelkopf 90° zurückversetzt
Angle Head 90°, Offset Type

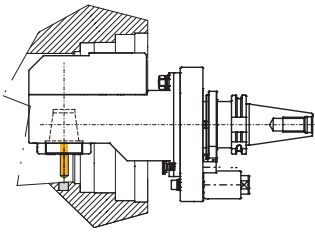

Zurückgesetzte Einheit mit vergrößerter nutzbarer Werkzeuglänge und Innenkühlung als Option.

Rear offset unit with increased usable tool length and internal coolant is an option.

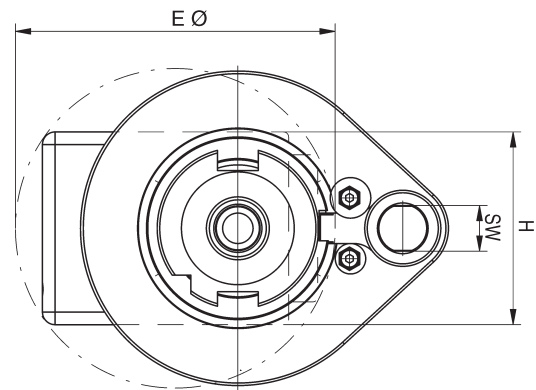
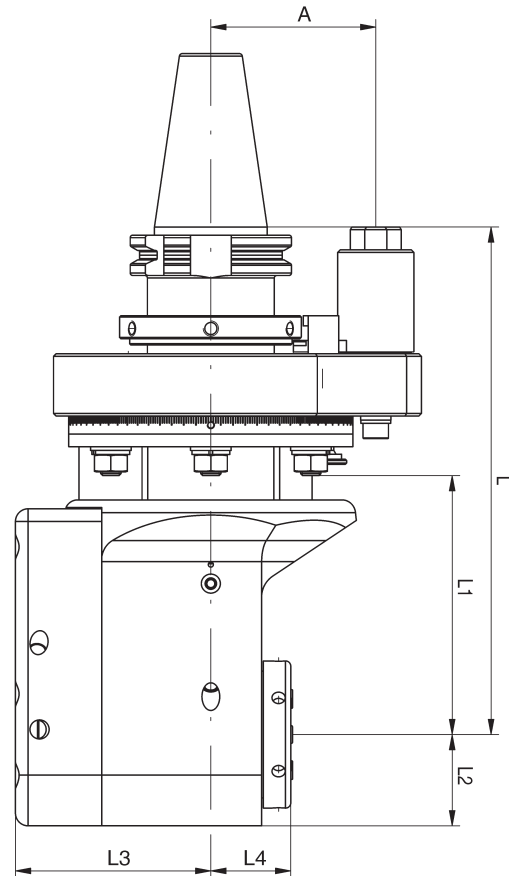
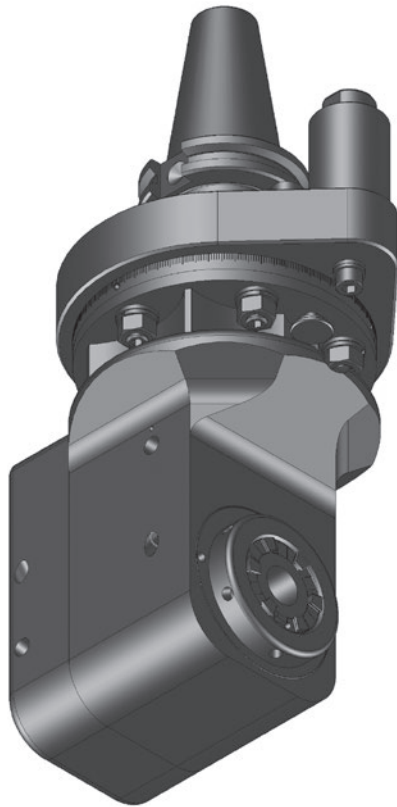

Baugröße Size	Bestell-Nr. / Order No.			Werkzeug Aufnahme Toolholder	Eintauch / Clearance Ø E mm		L3 mm		L4 mm	
	ohne / without	extern / external	intern / internal							
5	135401	162856	135415	ER 25	103	103	57,0	57,0	35,8	41,6
5	173521	162881	105451	mi 40	130	130	57,0	57,0	50,3	50,3
7	135391	162869	135417	ER 32	128	128	77,5	77,5	32,2	38,0
7	173526	162896	166538	mi 50	150	150	77,5	77,5	55,0	55,0

Baugröße Size	max. Drehmoment Torque max.	max. Drehzahl (U/min.) Rev. max. (RPM)	Übersetzung Gear Ratio	L mm	L1 mm	L2 mm	H mm	A mm	kg	SW
5	30 Nm	8.000	i = 1:1	180	80	28,5	57	65	6,5	18
7	70 Nm	6.000	i = 1:1	198	100	38,0	76	65	8,5	18

ANSI CAT 40 ZWS

Winkelkopf 90° zurückversetzt schmale Bauform
Angle Head 90°, Offset Slim Type

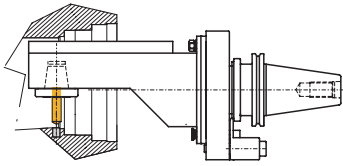

Zurückversetzte und schmale Bauform zum Eintauchen in kleine Bohrungen oder eingegengten Platzverhältnissen.

Offset narrow form to slide into small bores or when clearance issues / space restrictions are issue.



Achtung:
Drehrichtungsumkehr

Attention!
Reversal of rotation direction

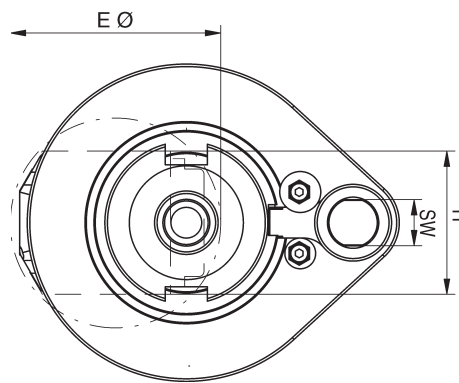
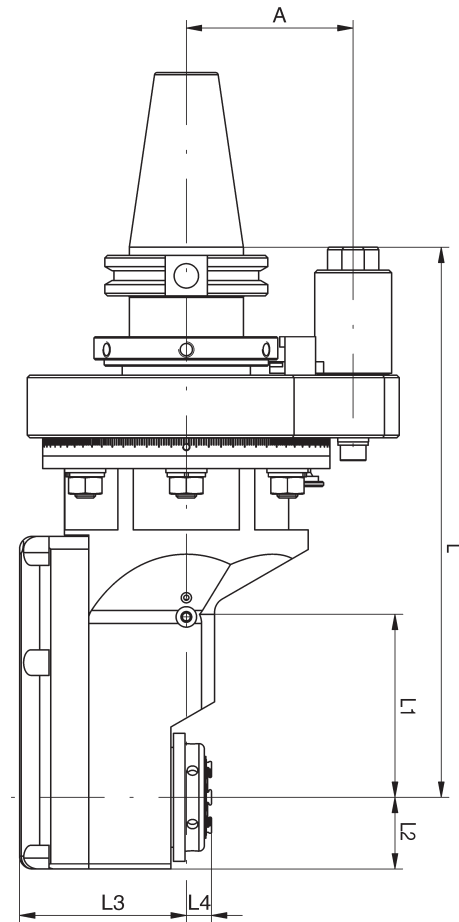
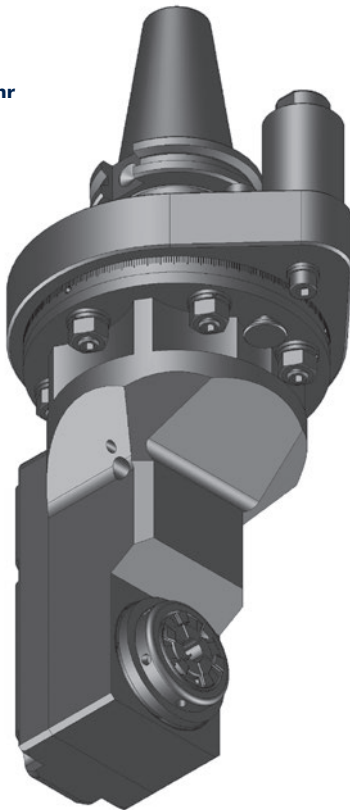

Baugröße Size	Bestell-Nr. / Order No.			Werkzeug Aufnahme Toolholder	Eintauch / Clearance Ø E mm		L3 mm		L4 mm	
	ohne / without	extern / external	intern / internal							
0	135613			ER 11	50		49,0		-8,0	
3	135614			ER 20	75		54,5		11,2	
3	162929			mi 32	100		54,5		26,0	
5	135619	162923		ER 25	82	82	65,0	65,0	10,0	10,0
5	173538	162935		mi 40	125	125	65,0	65,0	23,5	23,5

Baugröße Size	max. Drehmoment Torque max.	max. Drehzahl (U/min.) Rev. max. (RPM)	Übersetzung Gear Ratio	L mm	L1 mm	L2 mm	H mm	A mm	kg	SW
0	6 Nm	12.000	i = 1:1,67	213	38	20	36	65	7,0	18
3	15 Nm	10.000	i = 1:1	225	80	24	48	65	6,0	18
5	30 Nm	8.000	i = 1:1	215	76	28	56	65	6,5	18

ANSI CAT 40 WS

**Winkelschwenkeinheit 0-98°
Angle Head, Adjustable 0-98°**

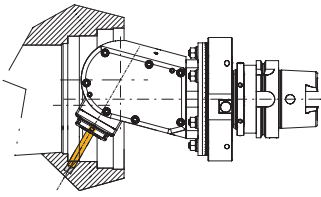

Einstellbare Winkelschwenkeinheit, um Bohr- und Fräsarbeiten in allen Winkeln durchführen zu können.

Adjustable angle unit to do boring and milling applications at any angle.

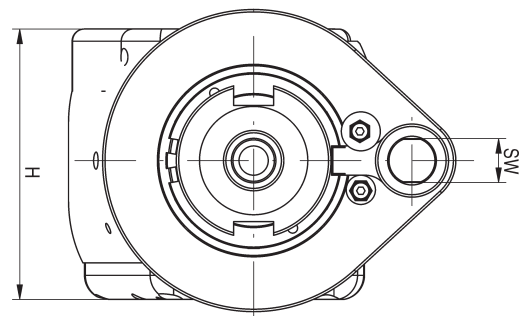
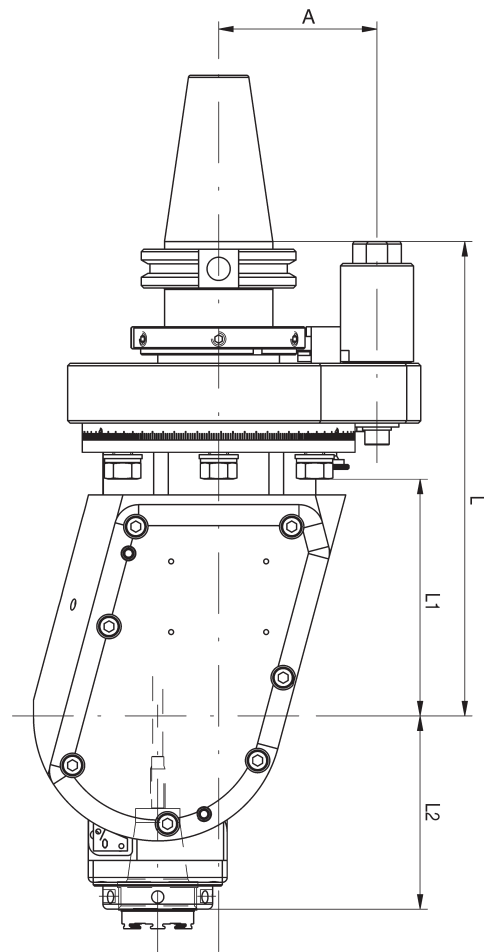
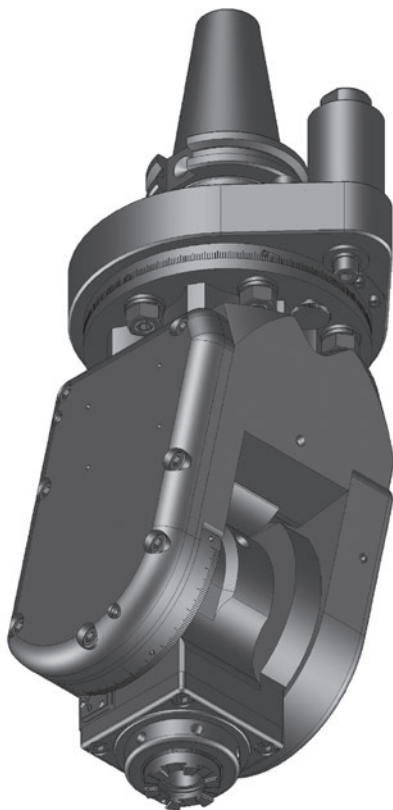

Baugröße Size	Bestell-Nr. / Order No. (i=1:1)		Bestell-Nr. / Order No. (i=1:2,25)		Werkzeug Aufnahme Toolholder	L2 mm	L4 mm
	ohne / without	intern / internal	ohne / without	intern / internal			
3	162797	135811	162800	162801	ER 20	75,0	20
3	156566	167896	156567	156568	mi 32	82,9	20
5	172227	135838	162717	135781	ER 25	84,0	25
5	162932	135817	162725	162724	mi 40	97,0	25

Baugröße Size	max. Drehmoment Torque max.	max. Drehzahl (U/min.) Rev. max. (RPM)	Übersetzung Gear Ratio	L mm	L1 mm	H mm	A mm	kg	SW
3	15 Nm	8.000 / 15.000	i = 1:1 / 1:2,25	189	91	96	65	8,0	18
5	30 Nm	7.000 / 13.500	i = 1:1 / 1:2,25	195	96	111	65	9,6	18

ANSI CAT 50 SW

**Winkelkopf 90°
Angle Head 90°**

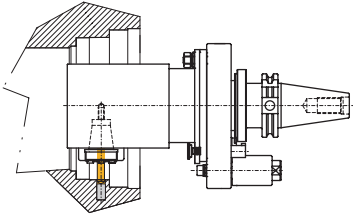

Für einzelne Bohr- und Fräsoperationen ohne räumliche Beschränkungen.

For single boring and milling operations without clearance issues.



Achtung:
Drehrichtungsumkehr

Attention!
Reversal of rotation direction

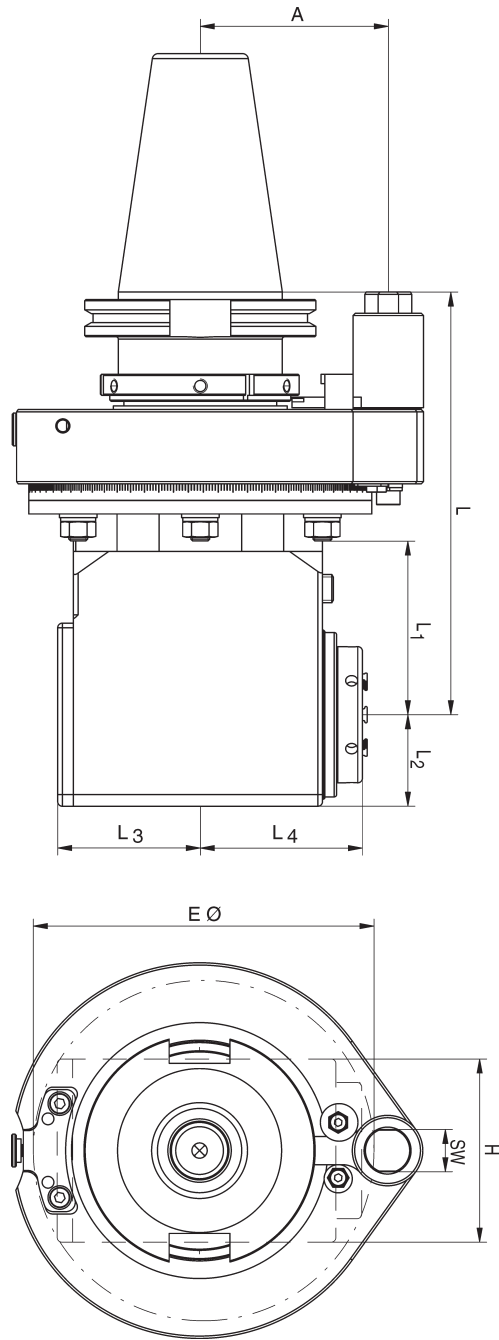
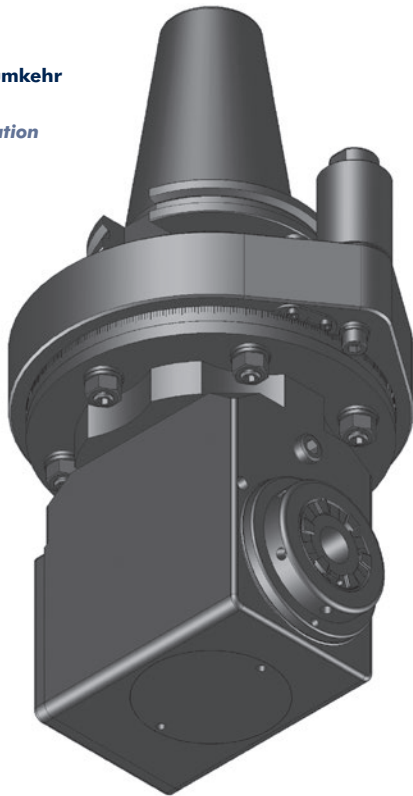

Baugröße Size	Bestell-Nr. / Order No.			Werkzeug Aufnahme Toolholder	Eintauch / Clearance Ø E mm		L3 mm		L4 mm	
	ohne / without	extern / external	intern / internal							
5	135420	162770	162771	ER 25	110	120	41,5	52	57,5	63,0
5	173068	162807	162808	mi 40	138	146	41,5	52	72,0	72,0
7	135471	162779	172905	ER 32	145	155	61,0	75	70,0	75,0
7	135472	162796	105525	mi 50	172	178	61,0	75	83,0	83,0
9	105553	162781	162782	ER 40	195	195	81,0	81	92,0	96,0
9	173505	162785	162786	mi 63	224	224	81,0	81	111,5	111,5

Baugröße Size	max. Drehmoment Torque max.	max. Drehzahl (U/min.) Rev. max. (RPM)	Übersetzung Gear Ratio	L mm	L1 mm	L2 mm	H mm	A mm	kg	SW
5	30 Nm	8.000	i = 1:1	180	75	34	68	80	10,5	18
7	70 Nm	6.500	i = 1:1	180	75	39	78	80	12,0	18
9	150 Nm	5.000	i = 1:1	215	105	52	104	80	18,0	18

ANSI CAT 50 DW

**Doppel-Winkelkopf 90°
Double Angle Head 90°**

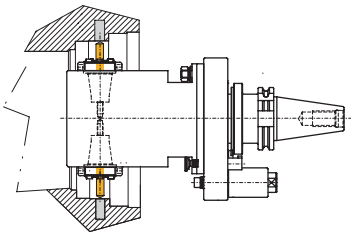

Doppelspindel um zwei entgegengesetzte Bohr- und Fräsoperationen durchführen zu können.

Double spindle unit to do two boring and milling operations in opposite directions.

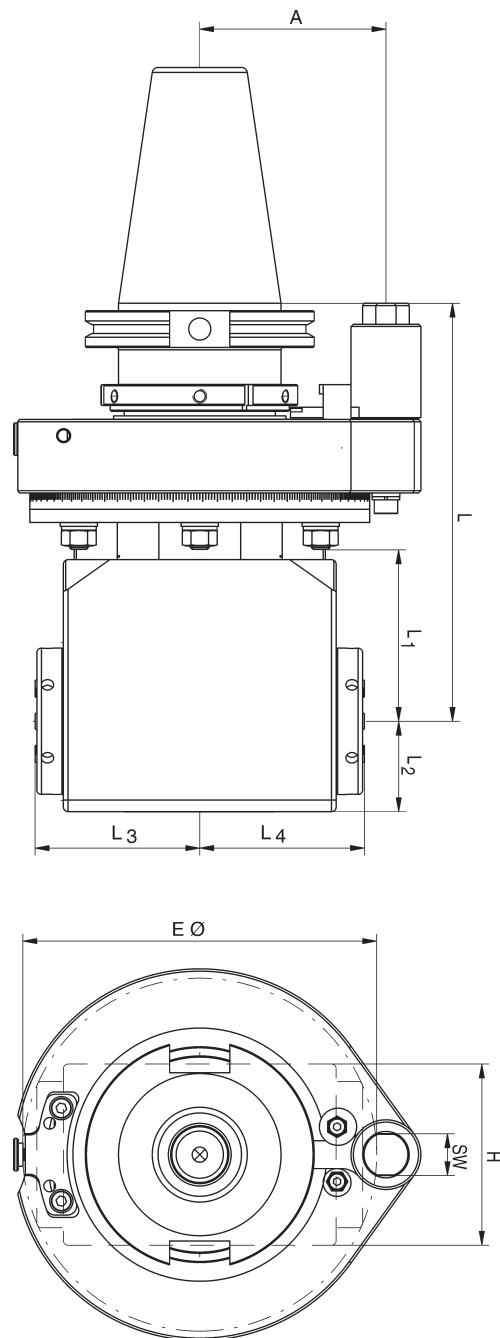
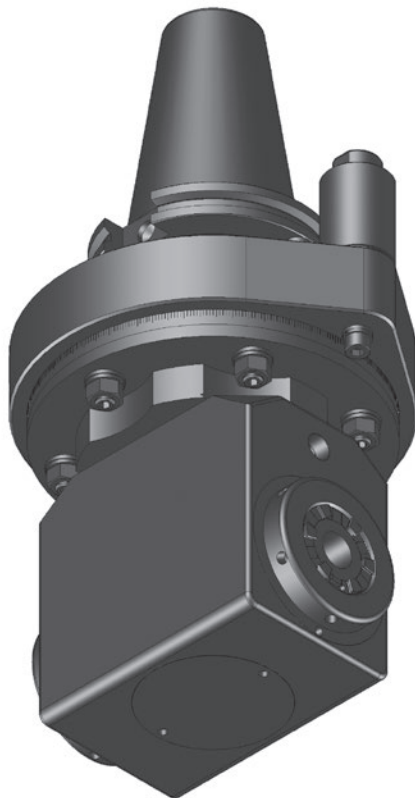

Baugröße Size	Bestell-Nr. / Order No.			Werkzeug Aufnahme Toolholder	Eintauch / Clearance Ø E mm		L3 mm		L4 mm	
	ohne / without	extern / external	intern / internal							
5	135723	135718		2 x ER 25	125	125	62,0	62,0	62,0	62,0
5	173512	162843		2 x mi 32	200	200	76,5	76,5	76,5	76,5
7	135725	162831		2 x ER 32	152	152	71,2	71,2	71,2	71,2
7	173517	162848		2 x mi 40	220	220	88,0	88,0	88,0	88,0
9	105789	162835		2 x ER 40	210	210	103,0	103,0	103,0	103,0
9	173519	162852		2 x mi 50	250	250	116,0	116,0	116,0	116,0

Baugröße Size	max. Drehmoment Torque max.	max. Drehzahl (U/min.) Rev. max. (RPM)	Übersetzung Gear Ratio	L mm	L1 mm	L2 mm	H mm	A mm	kg	SW
5	30 Nm	8.000	i = 1:1	180	70	34	68	80	11,5	18
7	70 Nm	6.500	i = 1:1	180	70	39	78	80	13,5	18
9	150 Nm	4.000	i = 1:1	215	109	58	108	80	20,0	18

ANSI CAT 50 ZW

Winkelkopf 90° zurückversetzt
Angle Head 90°, Offset Type

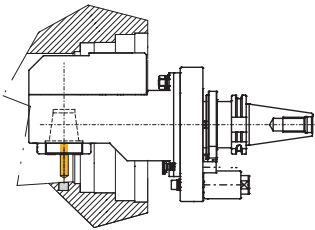

Zurückgesetzte Einheit mit vergrößerter nutzbarer Werkzeuglänge und Innenkühlung als Option.

Rear offset unit with increased usable tool length and internal coolant is an option.

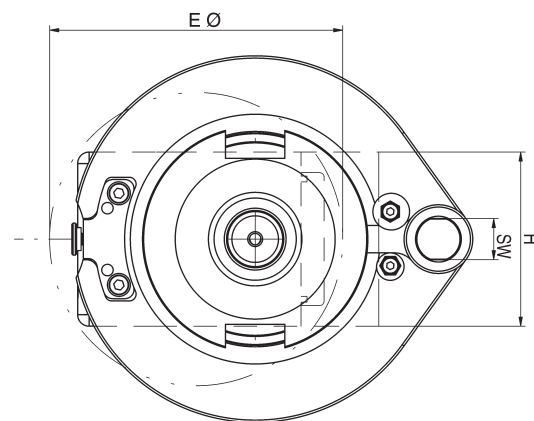
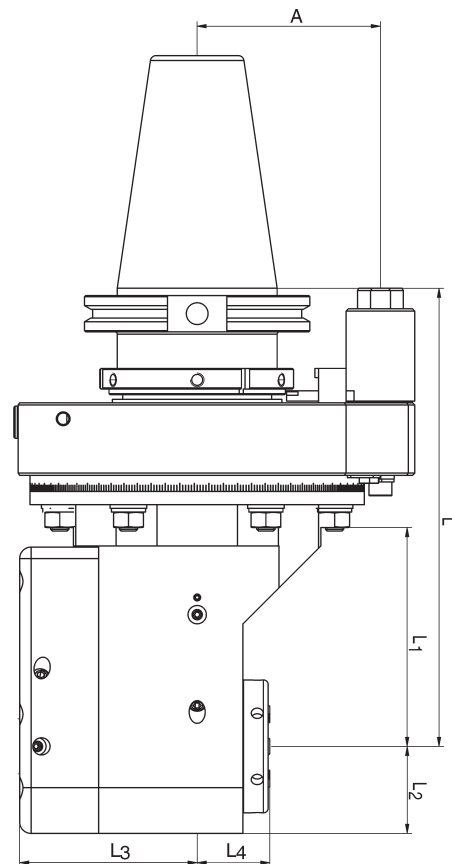
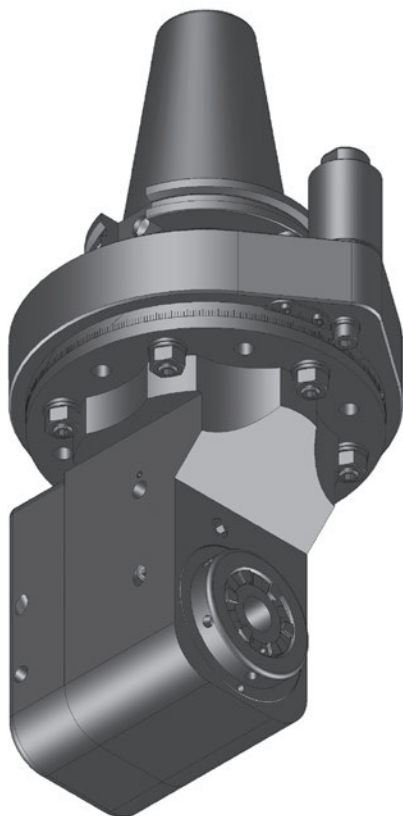

Baugröße Size	Bestell-Nr. / Order No.			Werkzeug Aufnahme Toolholder	Eintauch / Clearance Ø E mm		L3 mm		L4 mm	
	ohne / without	extern / external	intern / internal							
5	135371	162863	162864	ER 25	103	103	58,0	58,0	35,8	41,6
5	173524	162888	167846	mi 40	133	133	58,0	58,0	50,3	50,3
7	135374	162872	135379	ER 32	128	128	77,5	77,5	32,2	38,0
7	173530	162901	105480	mi 50	152	152	77,5	77,5	55,0	55,0
9	105448	162875	162877	ER 40	140	140	89,0	89,0	31,0	34,8
9	169045	162906	162907	mi 63	165	165	89,0	89,0	48,3	48,3

Baugröße Size	max. Drehmoment Torque max.	max. Drehzahl (U/min.) Rev. max. (RPM)	Übersetzung Gear Ratio	L mm	L1 mm	L2 mm	H mm	A mm	kg	SW
5	30 Nm	8.000	i = 1:1	185	79	28,5	57	80	11,5	18
7	70 Nm	6.000	i = 1:1	200	94	38,0	78	80	14,0	18
9	150 Nm	5.000	i = 1:1	260	152	52,0	104	80	19,0	18

ANSI CAT 50 ZWS

Winkelkopf 90° zurückversetzt schmale Bauform
Angle Head 90°, Offset Slim Type

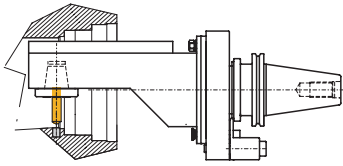

Zurückversetzte und schmale Bauform zum Eintauchen in kleine Bohrungen oder eingegengten Platzverhältnissen.

Offset narrow form to slide into small bores or when clearance issues / space restrictions are issue.



Achtung:
Drehrichtungsumkehr

Attention!
Reversal of rotation direction

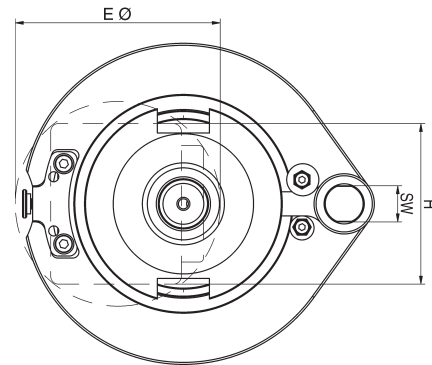
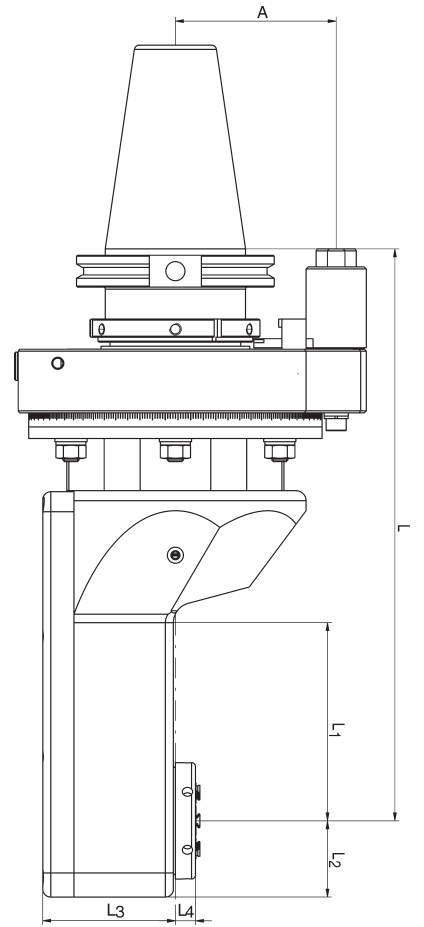
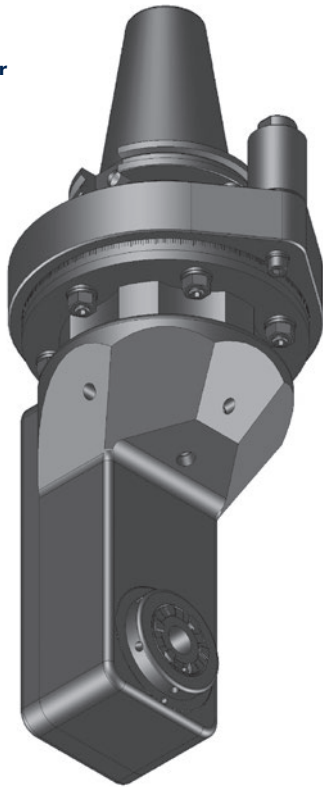

Baugröße Size	Bestell-Nr. / Order No.			Werkzeug Aufnahme Toolholder	Eintauch / Clearance Ø E mm		L3 mm		L4 mm	
	ohne / without	extern / external	intern / internal							
0	135591			ER 11	50		49		-8,0	
5	135620	167467		ER 25	82	82	65	65	10,0	10,0
5	173540	162939		mi 40	125	125	65	65	23,5	23,5
7	135653	162927		ER 32	102	102	66	66	13,0	13,0
7	135638	162943		mi 50	135	135	66	66	29,0	29,0

Baugröße Size	max. Drehmoment Torque max.	max. Drehzahl (U/min.) Rev. max. (RPM)	Übersetzung Gear Ratio	L mm	L1 mm	L2 mm	H mm	A mm	kg	SW
0	6 Nm	12.000	i = 1:1,67	227,5	38	20	36	80	11,0	18
5	30 Nm	8.000	i = 1:1	215,0	76	28	56	80	12,5	18
7	70 Nm	6.000	i = 1:1	285,0	100	38	80	80	13,5	18

ANSI CAT 50 WS

Winkelschwenkeinheit 0-98°
Angle Head, Adjustable 0-98°

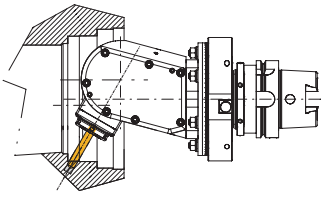

Einstellbare Winkelschwenkeinheit, um Bohr- und Fräsarbeiten in allen Winkeln durchführen zu können.

Adjustable angle unit to do boring and milling applications at any angle.

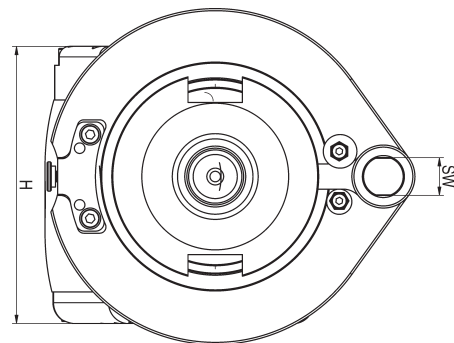
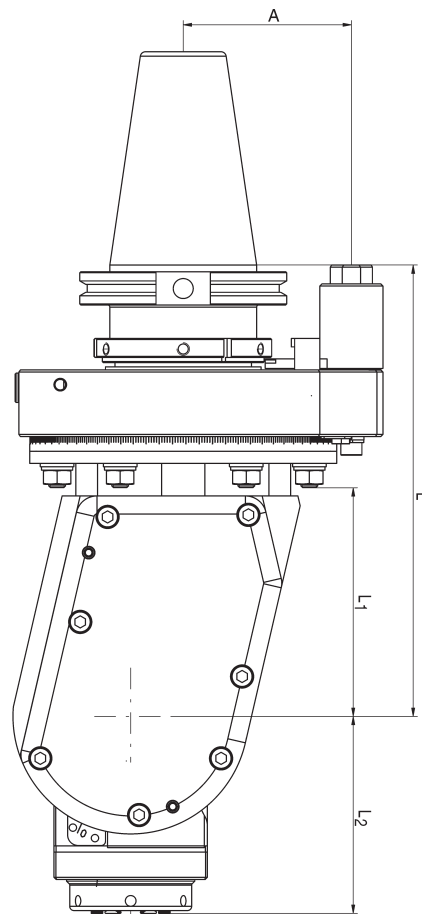
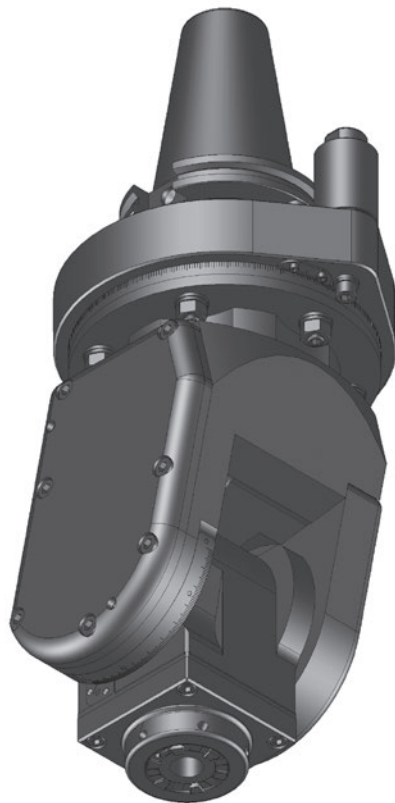

Baugröße Size	Bestell-Nr./Order No. (i=1:1)		Bestell-Nr./Order No. (i=1:2,25)		Werkzeug Aufnahme Toolholder	L2 mm	L4 mm
	ohne / without	intern / internal	ohne / without	intern / internal			
5	162946	135839	162947	162948	ER 25	84	25
5	162951	169978	162950	162949	mi 40	97	25
7	162984	162983			ER 32	95	25
7	162990	169941			mi 50	108	25

Baugröße Size	max. Drehmoment Torque max.	max. Drehzahl (U/min.) Rev. max. (RPM)	Übersetzung Gear Ratio	L mm	L1 mm	H mm	A mm	kg	SW
5	30 Nm	7.000 / 13.500	i = 1:1 / 1:2,25	195	100	111	80	14,0	18
7	70 Nm	6.000	i = 1:1	215	109	132	80	16,0	18

Zeichnung zum Anfrageformular Checklist for Inquiry

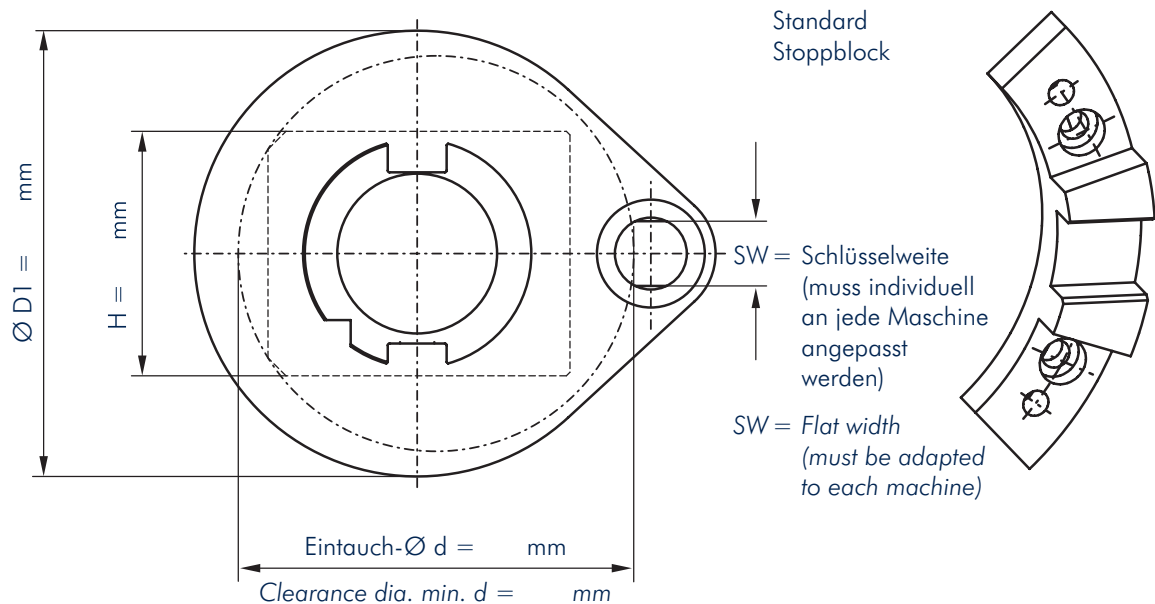
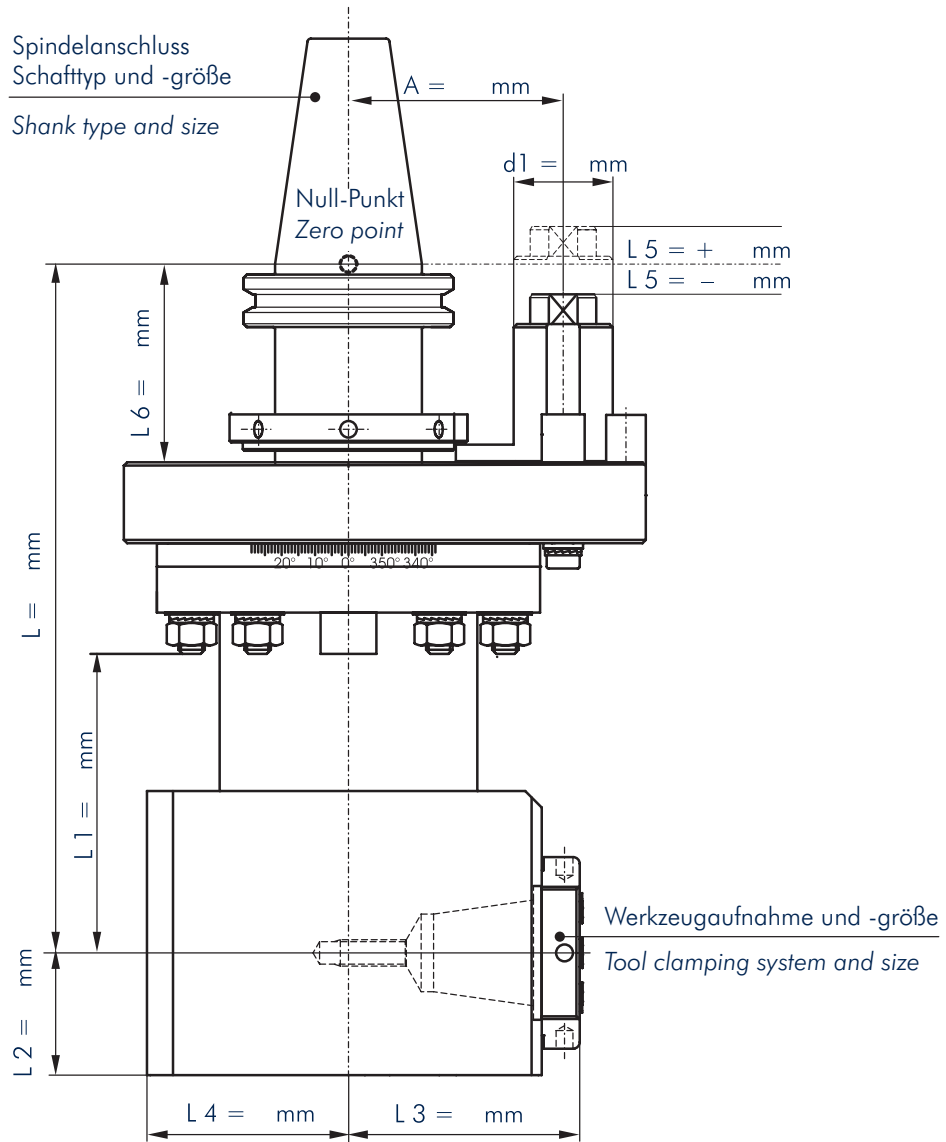

Anfrageformular / Request Form

Fax +49 831-57444-90

Firma / Company	
Ansprechpartner / Name	
Anschrift / Adress	
PLZ/Ort / Zip/City	
Telefon / Phone	
Telefax / Fax	
E-Mail / eMail	

Maschinenangaben / Machine Specs

Hersteller / Manufacturer	
Typ, Baujahr / Type, year of manufacturing	
Maschinennr. / Machine no.	
Innenkühlung Druck / Internal coolant pressure	
max. Spindel-Drehzahl / Spindle speed max.	U/min. / RPM
max. Spindel-Drehmoment / max. spindle torque	Nm
Abstützung vorhanden / Support available	ja / yes nein / no
Stoppblock vorhanden / Stop block available	ja / yes nein / no
Stoppblock-Zeichnung / Stop block drawing	ja (bitte übersenden) / yes (please transmit) nein / no
Werkzeugplätze (Magazin) / Tool places (magazine)	Stück / Pcs.

Bearbeitungsangaben / Operation Specs

Art der Bearbeitung / Operation	
(Bohren, Fräsen, Drehen) / (drilling, milling, turning)	
Werkstoff / Material	
Werkzeug / Tool	
Werkstückzeichnung / Work piece drawing	ja (bitte übersenden) / yes (please transmit) nein / no
Anzahl Abstützung / Number of supports	

Winkelkopf Angaben / Angle Head Specs

Spindelanschluss (Schaft) / Spindle connection (Shank)	SK	ANSI-CAT	MAS-BT	HSK
Andere / Others				
Schaftgröße (DIN) / Shank size (DIN)	Andere / Others			
Übersetzung / Gear ratio	i=			
Maße eintragen (Zeichnung) / Add dimensions (drawing)				
Aufnahme (1-Spindler) / Holder (One-spindle)				
Aufnahmen (Mehrspindler) / Holder (Multi-spindle)				
Verriegelung / Locking	ja / yes	nein / no		
Gewünschte Drehzahl / Desired spindle speed	U/min. / RPM			
Gewünschtes Drehmoment / Desired torque	Nm			
Achsversatz A / Offset A	mm			
Arretierbolzen Ø / Locking bolt Ø	mm			
Lage zum Nullpunkt / Position to zero point	+	-	mm	
max. Werkzeuggewicht / Tool weight max.	kg			
max. Werkzeug-Ø / Tool diameter max.	mm			
Autom. Werkzeugwechsel / Automatic tool change	ja / yes	nein / no		
Manueller Werkzeugwechsel / Manual tool change	ja / yes	nein / no		
Kühlmittel / Coolant	ja / yes	nein / no		
max. Kühlmitteldruck (i.K.) / max. coolant pressure (int.)				
Spritzdüse / Coolant nozzle				
Spritzrohr / Coolant pipe				
Zubehör / Accessories				

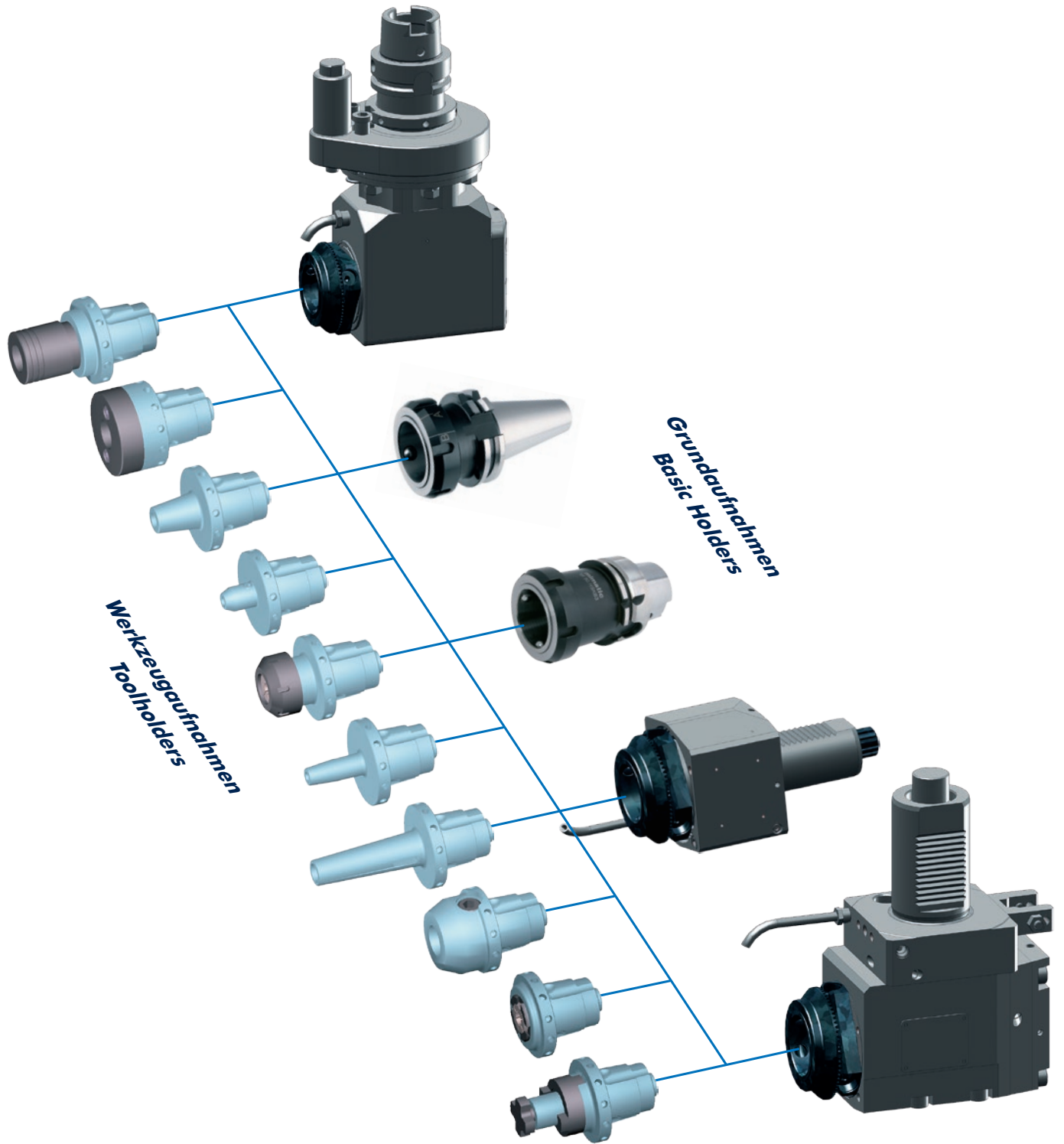

		Größe Size	Norm Standard	Seite Page
Grundaufnahmen Basic Toolholders		SK 40/50	DIN 69871	67
		BT 40/50	MAS-BT	67
		HSK 63	DIN 69893	67
Spannzangenaufnahmen Collet Chucks		ER 11 - ER 40	DIN 6499	68
Kombi-Aufsteckfräsdorne Combination Shell End Mill Arbors		Ø 16-27 mm		68
Weldon-Aufnahmen Whistle-Notch-Aufnahmen Weldon Toolholders Whistle-Notch Toolholders		Ø 6-25 mm Ø 1/4"-1/0"	DIN 1835 B DIN 1835 B	69 69
Synax® Gewinde-Schnellwechselfutter Synax® Tapping Quick Change Holders		Ø 3,5-16 mm		70
Softsynchro-Futter (Lizenz Emuge) Softsynchro Chucks (Licence Emuge)		M4-M12		70
Hydrodehn-Spannfutter Hydraulic Chucks		Ø 12 + 20 mm		68
		Zubehör / Accessories		74
Schrumpf-Spannfutter Shrink Fit Chucks		Ø 8-20 mm		71
		Zubehör / Accessories		71
Zubehör Accessories		Rohling / Blank		71
		Prüfdorn / Test mandrel		71
		Werkzeug-Voreinstellung / Tool-presetting unit		72
		Montageblock / Wrench		72
		Schutzstopfen / Protection plug		73
		Spannschlüssel / Assembling jig		73

Modulares Schnellwechselsystem "mimatic mi" für Winkelköpfe Modular Quick Change System "mimatic mi" for Angle Heads

Vorteile

- Durchgängiges Werkzeugspannsystem für alle Produktionsbereiche
- Voreinstellung der Werkzeuge außerhalb der Maschine durch Längeneinstellschraube
- Werkzeugwechsel innerhalb Sekunden
- Rundlaufgenauigkeit der Schnittstelle < 0,002 mm
- Sichere Drehmomentübertragung durch Formschluss
- Sehr kurze Bauweise
- Werkzeugaufnahmen in verschiedenen Baugrößen
- Alle Werkzeugaufnahmen mit innerer Kühlmittelzufuhr

Einsatz in Bearbeitungszentren

Angetriebene Werkzeuge für alle Bearbeitungszentren, Fräsmaschinen, Dreh- /Fräszentren sowie Transfer- und Spezialmaschinen. Winkelköpfe erhalten Sie in vielen verschiedenen Ausführungen:

- Schaftvarianten SK, BT, CAT, HSK
- Über- / Untersetzungen
- innere und / oder äußere Kühlmittelzufuhr
- schmale Bauform
- 90° Winkel
- Ein- und 2-Spindleinheiten
- zurückversetzt
- schlanke Bauform
- Winkelschwenk 0-98°

Modulare Werkzeugaufnahmen in verschiedenen Baugrößen für alle Produktionsbereiche

- Gewindeschneidfutter
- Spannzangenaufnahmen (innen- und außenliegend)
- Hydro-Flex Hydrodehnaufnahmen
- Schrumpfspannfutter
- Einschraubfräseraufnahmen
- MK Bohrer aufnahmen
- Weldon- und Whistle-Notch Aufnahmen
- Kombi-Aufsteckfräsdornaufnahmen

Dazu gibt es Werkzeugaufnahmen für Ihr Voreinstellgerät sowie Standard SK- / HSK-Aufnahmen als Basisgrundhalter.

"mi" Funktionsweise

- Einsetzen der Werkzeugaufnahme in die Spindel des Angetriebenen Werkzeuges
- 3 Kugeln innerhalb der modularen mimatic[®]-mi Schnittstelle führen die Aufnahme in die richtige Position
- Drehen der Aufnahme bis zum Einrasten
- Spannen der Überwurfmutter mittels mimatic[®] Einhandschlüssel
- Schnellwechselsystem lässt sich in umgekehrter Reihenfolge einfach lösen
- Die Plan- und Kegelanlage garantieren höchste Rundlaufgenauigkeit
- Alle Werkzeugaufnahmen besitzen innere Kühlmittelzufuhr und sind in verschiedenen Größen und Längen lieferbar

Advantages

- Universal tool clamping system for all production areas
- Presetting of the tools off-line by length adjustment screw
- Tool change within seconds
- Concentricity of the interface < 0,002 mm
- Secure holding force by form-locking
- Very short design
- Toolholders in different sizes
- All toolholders with internal coolant

Use on Machining Centers

Driven toolholders for all machining centers, milling machines, turn / mill centers as well as transfer and special machines. Angle heads are available in many different versions:

- Shafts such as SK, BT, CAT, HSK
- Gear multiplication or reduction
- Internal and/or external coolant supply
- 90° angle
- Single and double spindle units
- Offset type
- Slim design
- Adjustable 0-98°

Modular Toolholders in Different Sizes for All Production Areas

- Tapping toolholders
- Collet toolholders (internal and external nut)
- Hydro-Flex hydraulic toolholders
- Thread tightening toolholder cutters
- Morse taper shank toolholders
- Weldon and Whistle Notch toolholders
- Shell mill toolholders

All toolholders are available for use with your presetter.

"mi" Operation

- Insert the toolholder into the spindle of the driven toolholder
- 3 balls inside the modular mimatic mi interface guide the toolholder into the proper position
- Turn the toolholder until it is locked
- Clamping the sleeve nut by using the mimatic one hand key
- To unclamp the toolholder just follow all steps in reverse order
- The axial and conical surface guarantee highest concentricity
- All toolholders are with internal coolant and available in different sizes

Grundaufnahmen Basic Holders

DIN 69871 AD/B

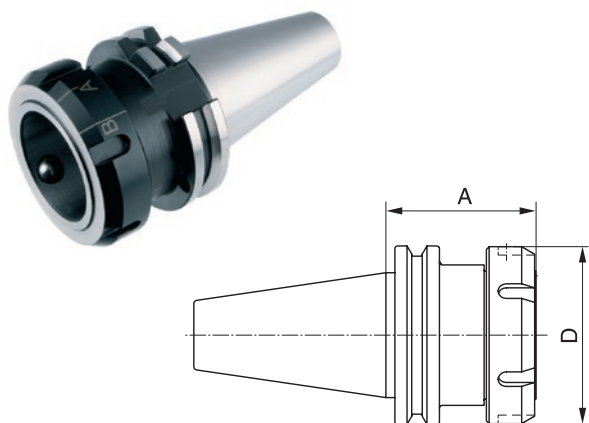

Bestell-Nr. Order No.	Größe Size	SK	A mm	D mm
121454	mi 32	SK 30	53,5	45
155404	mi 40	SK 40	53,5	54
155502	mi 50	SK 40	53,5	63
155481	mi 50	SK 50	53,5	63
155477	mi 63	SK 50	58,5	77

MAS-BT JIS 6339

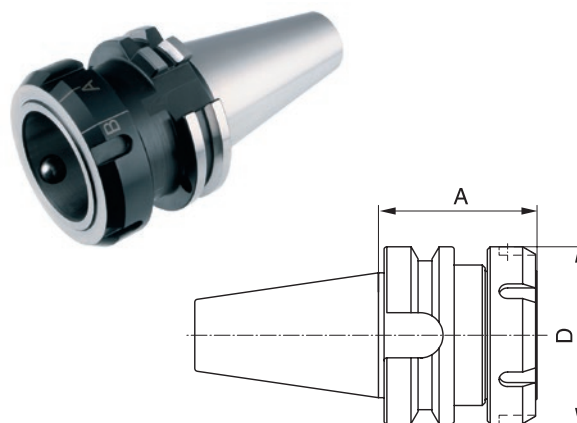

Bestell-Nr. Order No.	Größe Size	BT	A mm	D mm
121481	mi 32	BT 30	45,0	45
121512	mi 40	BT 40	48,5	54
155469	mi 50	BT 40	56,5	63
155457	mi 50	BT 50	61,5	63
121552	mi 63	BT 50	70,0	77

DIN 69893 A

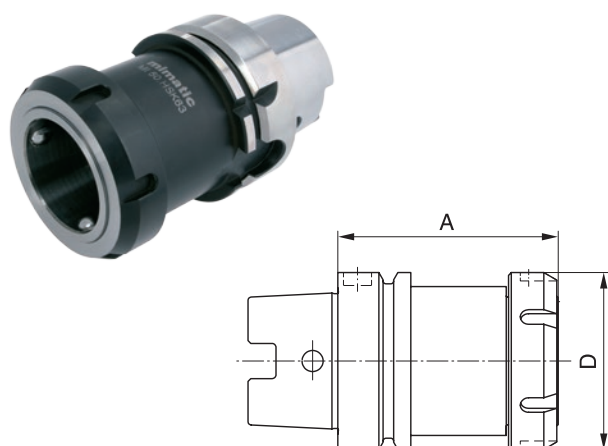

Bestell-Nr. Order No.	Größe Size	HSK	A mm	D mm
155410	mi 40	HSK 50	60,0	54
155458	mi 50	HSK 63	78,5	63
121562	mi 50	HSK 100	85,0	63
121577	mi 63	HSK 100	100,0	77

Zylinderschaft mit Spannfläche Cylindrical Shank With Clamping Surface

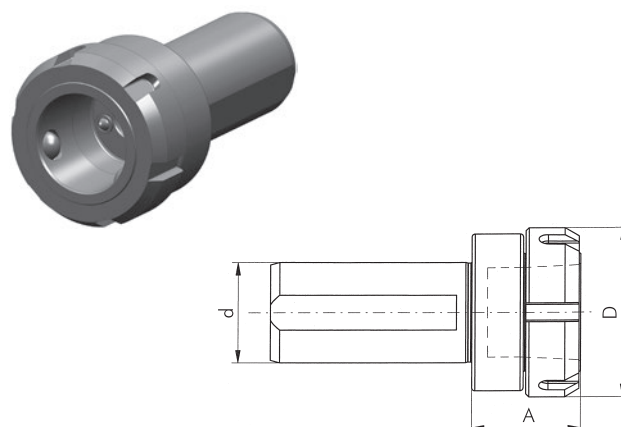

Bestell-Nr. Order No.	Größe Size	Ø d mm	A mm	D mm
180538	mi 40	32	35	54

Spannzangenaufnahme DIN 6499, Typ ER Collet Chucks DIN 6499, Type ER

- Kurze Ausführung / *Short Design*
- Spannmutter innenliegend / *Clamping Nut Inside*
- Mit innerer Kühlmittelzufuhr / *With Internal Coolant*

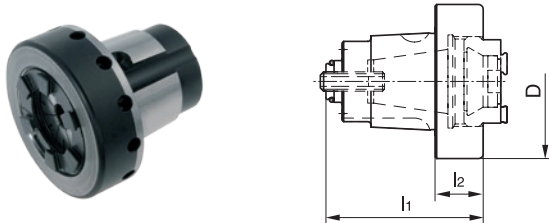

Bestell-Nr. Order No.	Größe Size	Spannzange Collet	l1 mm	l2 mm	D mm
121479	mi 32	ER 11	41,5	15	42
155357	mi 32	ER 16	41,5	15	42
171839	mi 32	ER 20	59,0	32	36
155388	mi 40	ER 16	45,0	11	48
155335	mi 40	ER 20	49,0	15	48
155367	mi 40	ER 25	55,0	21	48
155418	mi 50	ER 25	55,0	14	58
155460	mi 50	ER 32	59,0	18	58
155471	mi 63	ER 32	63,0	14	75
155496	mi 63	ER 40	69,0	20	75

- Lange Ausführung / *Long Design*
- Spannmutter außenliegend / *Clamping Nut outside*
- Mit innerer Kühlmittelzufuhr / *With Internal Coolant*

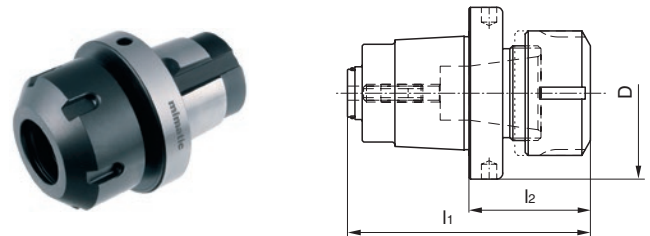

Bestell-Nr. Order No.	Größe Size	Spannzange Collet	l1 mm	l2 mm	D mm
155358	mi 32	ER 11	72,5	46,0	42
155319	mi 32	ER 16	64,5	38,0	42
121460	mi 40	ER 16	73,0	39,0	48
121502	mi 40	ER 20	80,0	46,6	48
155448	mi 50	ER 25	82,0	41,0	58
155445	mi 50	ER 32	88,0	47,0	58
155475	mi 63	ER 32	96,0	47,0	75
155451	mi 63	ER 40	94,5	45,5	75

Kombi-Aufsteckfräsdorn Combination Shell End Mill Arbor

Mit innerer Kühlmittelzufuhr / *With Internal Coolant*

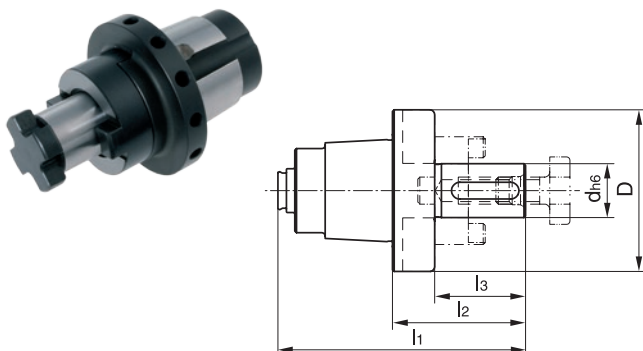

Bestell-Nr. Order No.	Größe Size	l1 mm	l2 mm	l3 mm	d h6 mm	D mm
121486	mi 32	66,0	39,5	27	16	42
155365	mi 40	73,5	39,5	25	16	48
155447	mi 50	82,0	41,0	27	16	58
155413	mi 50	88,0	47,0	31	22	58
155512	mi 63	96,0	47,0	31	22	75
155465	mi 63	98,0	49,0	33	27	75

Hydrodehn-Spannfutter Hydraulic Chuck

Mit innerer Kühlmittelzufuhr / *With Internal Coolant*
Spannhülsen Seite 74 / *Sleeves see page 74*

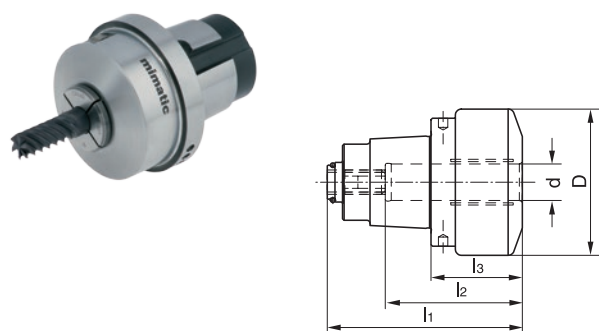

Bestell-Nr. Order No.	Größe Size	l1 mm	l2 mm	l3 mm	d h6 mm	D mm
155391	mi 40	64	45	30	12	48
155417	mi 50	71	52	30	20	58

Weldon-Aufnahme DIN 1835 B Weldon Toolholder DIN 1835 B

Mit innerer Kühlmittelzufuhr / *With Internal Coolant*

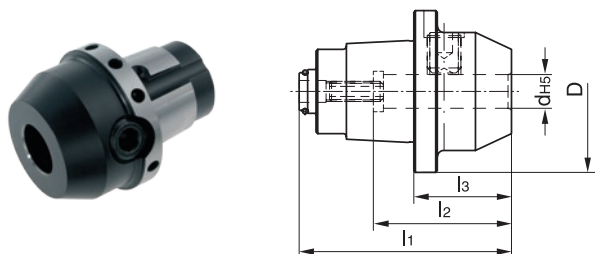

Bestell-Nr. Order No.	Größe Size	l1 mm	l2 mm	l3 mm	d H5 mm / "	D mm
121436	mi 32	52,5	37	26,0	6	42
121478	mi 32	52,5	37	26,0	8	42
121469	mi 32	55,5	41	29,0	10	42
121439	mi 32	57,5	46	31,0	12	42
121449	mi 32	52,5	37	26,0	1/4"	42
121472	mi 32	55,5	41	29,0	3/8"	42
121448	mi 32	57,5	46	31,0	1/2"	42
155330	mi 40	60,0	37	26,0	6	48
155346	mi 40	60,0	37	26,0	8	48
155321	mi 40	63,0	41	29,0	10	48
155331	mi 40	65,0	46	31,0	12	48
155326	mi 40	65,0	46	31,0	14	48
155379	mi 40	68,0	49	34,0	16	48
121497	mi 40	60,0	37	26,0	1/4"	48
121475	mi 40	63,0	41	29,0	3/8"	48
121474	mi 40	65,0	46	31,0	1/2"	48
121499	mi 40	68,0	49	34,0	5/8"	48
155419	mi 50	65,0	37	24,0	6	58
155411	mi 50	66,0	37	25,0	8	58
155400	mi 50	70,0	41	29,0	10	58
155406	mi 50	73,0	46	32,0	12	58
155412	mi 50	73,0	46	32,0	14	58
155407	mi 50	74,0	49	33,0	16	58
155427	mi 50	78,0	51	37,0	20	58
121489	mi 50	65,0	37	24,0	1/4"	58
121529	mi 50	40,0	41	29,0	3/8"	58
121525	mi 50	73,0	46	32,0	1/2"	58
121520	mi 50	75,0	49	34,0	5/8"	58
121526	mi 50	78,0	51	37,0	3/4"	58
155470	mi 63	81,0	37	32,0	6	75
155459	mi 63	82,0	37	33,0	8	75
155490	mi 63	85,0	41	36,0	10	75
155509	mi 63	88,5	46	39,5	12	75
155463	mi 63	88,5	46	39,5	14	75
155482	mi 63	91,0	49	42,0	16	75
155474	mi 63	93,0	51	44,0	20	75
155464	mi 63	110	59	61,0	25	75
166815	mi 63	81,0	37	32,0	1/4"	75
166805	mi 63	85,0	41	36,0	3/8"	75
166813	mi 63	88,5	46	39,5	1/2"	75
166807	mi 63	91,0	49	42,0	5/8"	75
166804	mi 63	93,0	51	44,0	3/4"	75
166812	mi 63	110	59	61,0	1/0"	75

Whistle Notch-Aufnahme DIN 1835 E Whistle Notch Toolholder DIN 1835 E

Mit innerer Kühlmittelzufuhr / *With Internal Coolant*

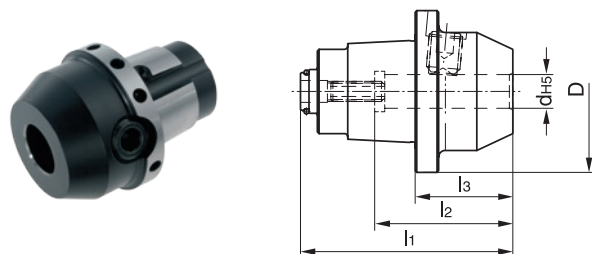

Bestell-Nr. Order No.	Größe Size	l1 mm	l2 mm	l3 mm	d H5 mm / "	D mm
121463	mi 32	52,5	36	26,0	6	42
121464	mi 32	52,5	36	26,0	8	42
121443	mi 32	55,5	40	29,0	10	42
121453	mi 32	57,5	45	31,0	12	42
121442	mi 32	52,5	36	26,0	1/4"	42
121485	mi 32	55,5	40	29,0	3/8"	42
121480	mi 32	57,5	45	31,0	1/2"	42
155369	mi 40	60,0	36	26,0	6	48
155363	mi 40	60,0	36	26,0	8	48
155370	mi 40	63,0	40	29,0	10	48
155364	mi 40	65,0	45	31,0	12	48
155333	mi 40	65,0	45	31,0	14	48
155382	mi 40	68,0	48	34,0	16	48
121492	mi 40	60,0	36	26,0	1/4"	48
121493	mi 40	63,0	40	29,0	3/8"	48
121455	mi 40	65,0	45	31,0	1/2"	48
121494	mi 40	68,0	48	34,0	5/8"	48
169197	mi 40	89,0	50	55,0	20	52
155416	mi 50	65,0	36	24,0	6	58
155401	mi 50	66,0	36	25,0	8	58
155383	mi 50	70,0	40	29,0	10	58
155408	mi 50	73,0	45	32,0	12	58
155435	mi 50	73,0	45	32,0	14	58
155436	mi 50	75,5	48	34,5	16	58
155384	mi 50	78,0	50	37,0	20	58
166816	mi 50	65,0	36	24,0	1/4"	58
155440	mi 50	70,0	40	29,0	3/8"	58
155434	mi 50	73,0	45	32,0	1/2"	58
155428	mi 50	75,0	48	34,0	5/8"	58
155385	mi 50	78,0	50	37,0	3/4"	58
166104	mi 63	81,0	36	32,0	6	75
166105	mi 63	82,0	36	33,0	8	75
166110	mi 63	85,0	40	36,0	10	75
166112	mi 63	88,5	45	39,5	12	75
166113	mi 63	88,5	45	39,5	14	75
166114	mi 63	91,0	48	42,0	16	75
166115	mi 63	93,0	50	44,0	20	75
166116	mi 63	110	56	61,0	25	75
166797	mi 63	81,0	36	32,0	1/4"	75
166799	mi 63	85,0	40	36,0	3/8"	75
166796	mi 63	88,5	45	39,5	1/2"	75
166803	mi 63	91,0	48	42,0	5/8"	75
166798	mi 63	93,0	50	44,0	3/4"	75
166795	mi 63	110	56	61,0	1/0"	75

SYNAX® Gewinde-Schnellwechselfutter SYNAX® Tapping Quick Change Holder

Ohne innerer KMZ, mit Synchronisation und Längenausgleich
Without Internal Coolant, With Synchronisation
and Length Compensation

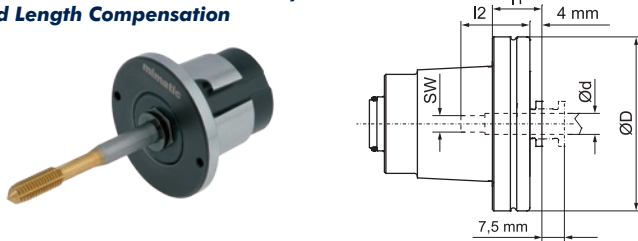

Bestell-Nr. Order No.	Größe Size	l1 mm	l2 mm	d mm	D mm	SW
121510	mi 40	17,0	25	3,5	48	2,7
155397	mi 40	17,0	25	4,5	48	3,4
155377	mi 40	17,0	27	6,0	48	4,9
155378	mi 40	17,0	27	8,0	48	6,2
155403	mi 40	38,0	28	9,0	48	7,0
121451	mi 40	38,0	29	10,0	48	8,0
121498	mi 40	38,0	30	12,0	48	9,0
155450	mi 50	16,5	25	3,5	58	2,7
155487	mi 50	16,5	25	4,5	58	3,4
155422	mi 50	16,5	27	6,0	58	4,9
155497	mi 50	16,5	27	7,0	58	5,5
155455	mi 50	16,5	27	8,0	58	6,2
155423	mi 50	16,5	28	9,0	58	7,0
155466	mi 50	16,5	29	10,0	58	8,0
155472	mi 50	44,0	36	11,0	58	9,0
155449	mi 50	16,5	30	12,0	58	9,0
155479	mi 50	44,0	33	16,0	58	12,0

Mit innerer Kühlmittelzufuhr (70 bar), nur Synchronisation
With Internal Coolant (70 bar), Only Synchronisation

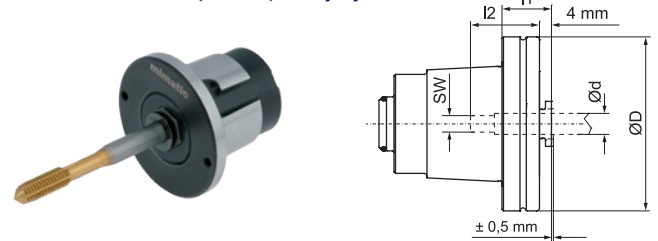

Bestell-Nr. Order No.	Größe Size	l1 mm	l2 mm	d mm	D mm	SW
155389	mi 40	17,0	27	6	48	4,9
121522	mi 40	17,0	27	8	48	6,2
121515	mi 40	38,0	28	9	48	7,0
121504	mi 40	38,0	29	10	48	8,0
121517	mi 40	38,0	30	12	48	9,0
155432	mi 50	16,5	27	6	58	4,9
172720	mi 50	16,5	27	7	58	5,5
155498	mi 50	16,5	27	8	58	6,2
155473	mi 50	16,5	28	9	58	7,0
155467	mi 50	16,5	29	10	58	8,0
155446	mi 50	16,5	30	12	58	9,0
121534	mi 50	44,0	33	16	58	12,0

Softsynchro-Futter (Lizenz Emuge) Softsynchro Chuck (Licence Emuge)

Mit innerer KMZ, mit Längenausgleich ± 0,5 mm auf Zug + Druck
With Internal Coolant and Push + Pull Length Compensation
± 0,5mm

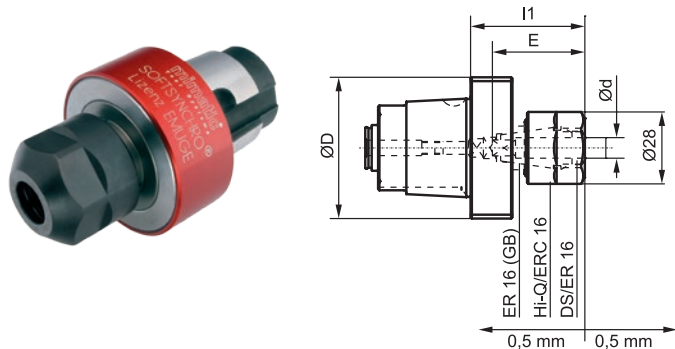

Bestell-Nr. Order No.	Größe Size	Spannzange Collet	Gewinde Thread	l1 mm	d mm	D mm
121503	mi 40	ER-GB 16	M4-M12	47,5	4,5-10	45
121530	mi 50	ER-GB 16	M4-M12	44,5	4,5-10	50

Spannfutter mit Längenausgleich für Spannzangen Chuck with Length Compensation for Collets

Mit innerer KMZ, mit Längenausgleich ± 0,5 mm auf Zug + Druck
With Internal Coolant and Push + Pull Length Compensation
± 0,5mm

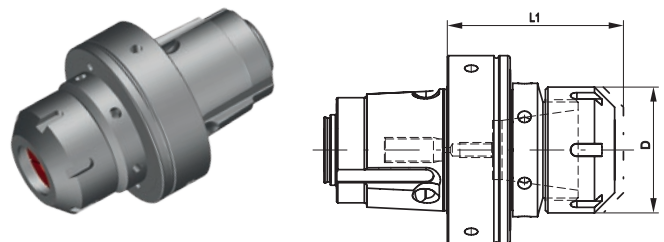

Bestell-Nr. Order No.	Größe Size	Spannzange Collet	L1 mm	D mm
121518	mi 40	ER 20 GB(1-13)	60	28
155488	mi 50	ER 25 GB(1-16)	60	42
155491	mi 63	ER 32 GB(2-20)	70	50

Schrumpf-Spannfutter Shrink Fit Chuck

Mit innerer Kühlmittelzufuhr
With Internal Coolant

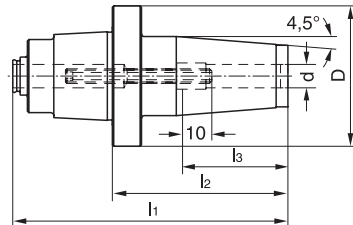

Bestell-Nr. Order No.	Größe Size	l1 mm	l2 mm	l3 mm	d h6 mm	D mm
155381	mi 40	94	60	36	8	48
121482	mi 40	94	60	42	10	48
155334	mi 40	99	65	47	12	48
121501	mi 40	104	70	50	16	48
155421	mi 50	101	60	36	8	58
155409	mi 50	101	60	42	10	58
155444	mi 50	106	65	47	12	58
155438	mi 50	106	65	47	14	58
155430	mi 50	111	70	50	16	58
155431	mi 50	116	75	50	18	58
155454	mi 50	116	75	52	20	58

Zubehör für Schrumpf-Spannfutter Accessory for Shrink Fit Chucks

Reduzierhülse
Sleeve

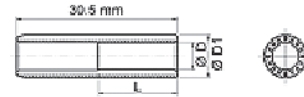

Bestell-Nr. Order No.	L mm	L1 mm	d h6 mm	D mm
119807	30,5	7,5	2,5	8
119787	30,5	9,0	3,0	8
119808	30,5	10,5	3,5	8
119809	30,5	12,0	4,0	8
119788	30,5	13,5	4,5	8
119789	30,5	15,0	5,0	8
119796	30,5	16,5	5,5	8

Rohling Blank

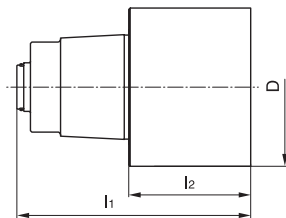

Bestell-Nr. Order No.	Größe Size	l1 mm	l2 mm	D mm
121457	mi 32	76,5	50	42
166791	mi 40	94,0	60	48
166789	mi 50	111,0	70	58
121557	mi 63	129,0	80	75

Prüfdorn Test Mandrel

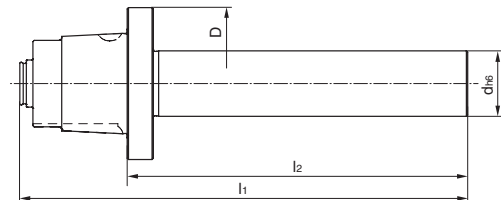

Bestell-Nr. Order No.	Größe Size	l1 mm	l2 mm	d H7 mm	D mm
170569	mi 25		110	14	35
172991	mi 32		110	18	42
156208	mi 40		130	20	48
156082	mi 50		130	25	58
172992	mi 63		150	32	75

Aufnahme zur Werkzeug-Voreinstellung Tool Presetting Unit

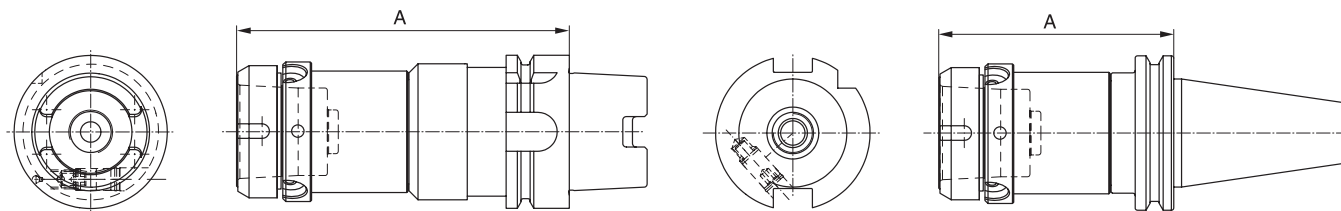

Bestell-Nr. Order No.	Größe Size	HSK	A mm
171098	mi 25	63	130,0
155352	mi 32	63	130,0
155380	mi 40	63	134,5
173224	mi 40	100	143,0
155429	mi 50	63	136,9
168301	mi 50	100	143,0
166990	mi 63	63	147,0
169267	mi 63	100	155,0

Bestell-Nr. Order No.	Größe Size	SK	A mm
121471	mi 40	40	95
121491	mi 40	50	128
155405	mi 50	40	97
121527	mi 50	50	140
155504	mi 63	50	140

Montageblock Assembling Jig

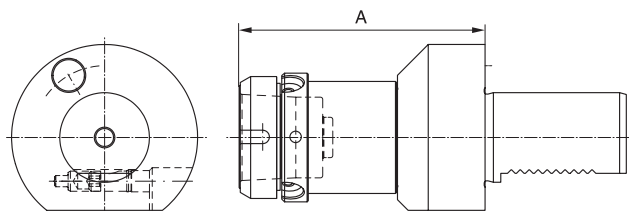

Bestell-Nr. Order No.	Größe Size	VDI	A mm
155368	mi 40	40	108
155356	mi 50	40	110
155372	mi 40	50	108
121524	mi 50	50	110



Bestell-Nr. Order No.	Größe Size
166774	SK 40
166775	HSK 63
121571	VDI 40
121558	VDI 30
121579	SK 50
168300	HSK 100

mi Zubehör
mi Accessories

Komplett-Spannschlüssel für Einhandbedienung
Complete Wrench for One-hand Operation



Bestell-Nr. Order No.	Größe Size
170734	mi 25, mi 32, mi 40

Drehmomentschlüssel für mi
Torque Wrench for mi



Bestell-Nr. Order No.	Größe Size	Nm
189909	mi 32, mi 40	8
183625	mi 50, mi 63	12

Schutzstopfen
Protection Plug



Bestell-Nr. Order No.	Größe Size
174460	mi 32
174458	mi 40
174457	mi 50
174459	mi 63

Ersatzteil für Drehmomentschlüssel
Asseccory for Torque Wrench



Bestell-Nr. Order No.	Größe Size	L mm	SW Wrench size
173985	mi 25 – mi 63	50	1/4"

Capto C4 Zubehör
Capto C4 Accessories

Spannschlüssel
Wrench



Bestell-Nr. Order No.	Größe Size
190203	C4

Zubehör für Hydrodehn-Spannfutter Accessories for Hydraulic Chucks

Reduzierhülse Sleeve

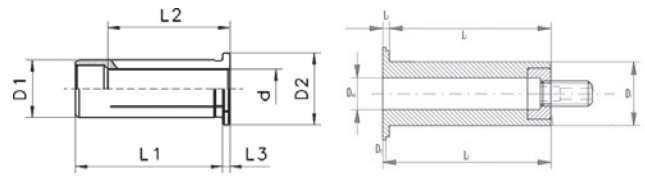

ohne Längeneinstellung
without horizontal adjustment

mit Längeneinstellung
with horizontal adjustment

Bestell-Nr. Order No.	D1 mm	d h6 mm / "	L1 mm	L2 mm	L3 mm	D2 mm
119790	12	3	40	29	4	16
119793	12	1/8"	40	29	4	16
119797	12	4	40	29	4	16
119798	12	3/16"	40	29	4	16
119819	12	5	40	29	4	16
119812	12	6	40	36	4	16
119813	12	1/4"	40	36	4	16
119791	12	7	40	37	4	16
119799	12	5/16"	40	37	4	16
119810	12	8	40	37	4	16
119792	12	9	40	37	4	16
119815	12	3/8"	40	40	4	16
119814	12	10	40	40	4	16
119816	20	3	50	28	4	25
119823	20	1/8"	50	28	4	25
119817	20	4	50	28	4	25
119837	20	3/16"	50	28	4	25
119800	20	5	50	28	4	25
119801	20	6	50	36	4	25
119822	20	1/4"	50	36	4	25
119818	20	7	50	38	4	25
119839	20	5/16"	50	37	4	25
119820	20	8	50	37	4	25
119802	20	9	50	38	4	25
119838	20	3/8"	50	38	4	25
119824	20	10	50	40	4	25
119825	20	11	50	40	4	25
119830	20	7/16"	50	45	4	25
119826	20	12	50	45	4	25
119821	20	1/2"	50	45	4	25
119827	20	14	50	45	4	25
119846	20	9/16"	50	45	4	25
119829	20	5/8"	50	48	4	25
119828	20	16	50	48	4	25
119847	25	3	56	29	4	30
119848	25	4	56	29	4	30
119831	25	5	56	29	4	30
119849	25	6	56	37	4	30
119832	25	7	56	37	4	30
119833	25	8	56	37	4	30
119834	25	9	56	38	4	30
119850	25	10	56	40	4	30

Bestell-Nr. Order No.	D1 mm	d h6 mm / "	L1 mm	L2 mm	L3 mm	D2 mm
119835	25	12	56	46	4	30
119851	25	14	56	47	4	30
119836	25	16	56	48	4	30
119841	25	18	56	48	4	30
119842	25	20	56	50	4	30
119844	32	6	60	36	4	36
119857	32	1/4"	60	36	4	36
119845	32	7	60	37	4	36
119879	32	5/16"	60	36	4	36
119852	32	8	60	36	4	36
119855	32	9	60	37	4	36
119884	32	3/8"	60	37	4	36
119864	32	10	60	40	4	36
119853	32	11	60	40	4	36
119858	32	12	60	45	4	36
119856	32	1/2"	60	45	4	36
119859	32	13/16"	60	45	4	36
119865	32	14	60	46	4	36
119854	32	15/16"	60	46	4	36
119861	32	5/8"	60	46	4	36
119866	32	16	60	48	4	36
119870	32	18	60	49	4	36
119878	32	3/4"	60	50	4	36
119877	32	20	60	50	4	36
119867	32	25	60	56	4	36

mit Längeneinstellung / with horizontal adjustment

119909	20	6	50	52	-	28
119889	20	8	50	52	-	28
152696	20	10	50	52	-	28
119910	20	12	50	52	-	28
119901	20	14	50	52	-	28
119911	20	16	50	52	-	28
119892	20	18	50	52	-	28
119893	25	10	56	59	-	32
119912	25	12	56	59	-	32
119894	25	14	56	59	-	32
119895	25	16	56	59	-	32
167144	25	18	56	59	-	32
167045	25	20	56	59	-	32

Zubehör Accessories

Spannschlüssel und Spannmuttern Wrenches and Clamping Nuts



Spannschlüssel für ER-Spannmuttern Wrench for ER Clamping Nuts

Bestell-Nr. Order No.	Größe Size	Typ
112912	ER 11	innenliegend / <i>inlying</i>
112954	ER 16	innenliegend / <i>inlying</i>
112929	ER 20	innenliegend / <i>inlying</i>
112913	ER 25	innenliegend / <i>inlying</i>
112900	ER 32	innenliegend / <i>inlying</i>
112867	ER 40	innenliegend / <i>inlying</i>
107628	ER 40	außenliegend / <i>outlying</i>

ER-Spannmuttern ER Clamping Nuts

Bestell-Nr. Order No.	Größe Size	Typ	Kühlung Coolant
112953	ER 11	innenliegend / <i>inlying</i>	
112860	ER 16	innenliegend / <i>inlying</i>	
112938	ER 20	innenliegend / <i>inlying</i>	
112961	ER 25	innenliegend / <i>inlying</i>	
112977	ER 32	innenliegend / <i>inlying</i>	
112946	ER 40	innenliegend / <i>inlying</i>	
112962	ER 16	innenliegend / <i>inlying</i>	✓
112940	ER 20	innenliegend / <i>inlying</i>	✓
112901	ER 25	innenliegend / <i>inlying</i>	✓
112963	ER 32	innenliegend / <i>inlying</i>	✓
112978	ER 40	innenliegend / <i>inlying</i>	✓
112513	ER 40	außenliegend / <i>outlying</i>	
117744	ER 40	außenliegend / <i>outlying</i>	✓

Hakenschlüssel zum Gegenhalten Hook Wrench to Hold Against

DIN 1810 A

mit Nase / *with nose*



DIN 1810 B

mit Zapfen / *with pivot*



Bestell-Nr. Order No.	Größe Size	Typ	DIN 1810
107557	ER 16	innenliegend / <i>inlying</i>	B
107608	ER 20	innenliegend / <i>inlying</i>	B
107446	ER 25	innenliegend / <i>inlying</i>	B
107558	ER 25	außenliegend / <i>outlying</i>	A
107642	ER 32	innenliegend / <i>inlying</i>	B
107607	ER 32	außenliegend / <i>outlying</i>	B
107566	ER 40	innenliegend / <i>inlying</i>	A
107628	ER 40	außenliegend / <i>outlying</i>	A
107605		Kreissägehalter / <i>Circular saw holder</i>	A
107447		Fräsdorn 22 / <i>Milling arbor 22</i>	B

Spannzangen DIN 6499-B Collets DIN 6499-B

■ Rundlaufgenauigkeit 6 µm
Concentricity 6 µm

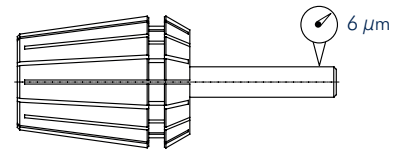

D mm	Bestell-Nr. / Order No.					
	ER 11	ER 16	ER 20	ER 25	ER 32	ER 40
1,0	120006	120055				
1,5	119994	120084				
2,0	119995	120068	120166	120187		
2,5	120031	120078	120182	120161		
3,0	120013	120071	120175	120223	120431	120586
3,5	120022	120096	120191	120224	120465	120600
4,0	120000	120097	120168	120245	120473	120581
4,5	120023	120074	120209	120253	120475	120565
5,0	120002	120099	120176	120271	120491	120628
5,5	120004	120083	120145	120229	120523	120616
6,0	120015	120112	120210	120281	120448	120637
6,5	120008	120115	120192	120264	120449	120638
7,0	120048	120108	120193	120238	120540	120655
7,5		120119	120203	120298	120467	120673
8,0		120120	120205	120255	120514	120582
8,5		120122	120178	120299	120496	120682
9,0		120124	120151	120291	120532	120621
9,5		120125	120152	120217	120567	120649
10,0		120130	120218	120300	120568	120676
10,5			120211	120292	120515	120630
11,0			120212	120274	120517	120631
11,5			120207	120277	120518	120679
12,0			120208	120270	120571	120641
12,5			120196	120316	120572	120650
13,0			120180	120279	120544	120684
13,5				120317	120552	120667
14,0				120287	120545	120653
14,5				120353	120536	120642
15,0				120318	120508	120608
15,5				120355	120583	120658
16,0				120261	120546	120643
16,5					120592	120624
17,0					120561	120681
17,5					120562	120635
18,0					120528	120644
18,5					120595	120718
19,0					120584	120693
19,5					120585	120694
20,0					120578	120669
20,5						120695
21,0						120705
21,5						120727
22,0						120662
22,5						120715
23,0						120707
23,5						120670
24,0						120671
24,5						120745
25,0						120756
25,5						120738
26,0						120672
Satz / Set	120049	120131	120154	120349	120612	120730
Satz / Set *		152712	120174	152713	152715	152716

ER Dichtscheiben
ER Seal Disc

Dichtbereich mm Tightness range mm	Bestell-Nr. / Order No.				
	ER 16	ER 20	ER 25	ER 32	ER 40
3,0 - 2,5	172713	163519	112863	112704	112910
3,5 - 3,0	163517	160220	112838	112830	112927
4,0 - 3,5	173372	163518	112833	112705	112951
4,5 - 4,0	160212	160221	112888	112743	112883
5,0 - 4,5	163515	163520	112753	112726	112884
5,5 - 5,0	160214	160222	112707	112734	112899
6,0 - 5,5	112891	112744	112871	112831	112959
6,5 - 6,0	160215	160223	112889	112810	112936
7,0 - 6,5	163516	112855	112839	112832	112846
7,5 - 7,0	160216	160224	112814	112760	112919
8,0 - 7,5	112897	112865	112817	112834	112911
8,5 - 8,0	160217	160225	112864	112780	112960
9,0 - 8,5	178391	163521	112890	112835	112952
9,5 - 9,0	160218	160227	112708	112706	112945
10,0 - 9,5	172458	112844	112811	112725	112821
10,5 - 10,0		160228	112843	112732	112908
11,0 - 10,5		163522	112752	112779	112916
11,5 - 11,0		160230	112852	112803	112841
12,0 - 11,5		112892	112861	112733	112924
12,5 - 12,0		160231	112812	112825	112925
13,0 - 12,5		160232	112870	112804	112894
13,5 - 13,0			112836	112826	112909
14,0 - 13,5			112798	112827	112881
14,5 - 14,0			112813	112699	112933
15,0 - 14,5			112862	112688	112942
15,5 - 15,0			112879	112805	112856
16,0 - 15,5			112837	112806	112822
16,5 - 16,0				112828	112943
17,0 - 16,5				112809	112770
17,5 - 17,0				112716	112842
18,0 - 17,5				112769	112762
18,5 - 18,0				112807	112917
19,0 - 18,5				112797	112882
19,5 - 19,0				112689	112895
20,0 - 19,5				112829	112845
20,5 - 20,0					112857
21,0 - 20,5					112823
21,5 - 21,0					112896
22,0 - 21,5					112934
22,5 - 22,0					112918
23,0 - 22,5					112944
23,5 - 23,0					112926
24,0 - 23,5					112858
24,5 - 24,0					112935
25,0 - 24,5					112771
25,5 - 25,0					112950
26,0 - 26,5					112824
Satz / Set	167490	112907	112735	112715	166918

Gewindebohrzangen Typ GB ohne Längenausgleich

Threading Collets Type BG Without Length Compensation

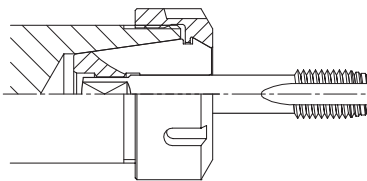

D mm	Vierkant Square	Norm Standard	Bestell-Nr. / Order No.							
			ER 11	ER 16	ER 20	ER 25	ER 32	ER 40	ER 50	
2,8	2,1	DIN	120753							
3,5	2,7	DIN	120807							
4,0	3,0	DIN	120842							
4,0	3,15/3,2	ISO, JIS	161023	120822	120858	120830	120874			
4,5	3,4	DIN	120878	120823	120824	120903	120917			
5,0	4,0	ISO, JIS	161024	120879	120891	120911	120899			
5,5	4,3	DIN		120884	120897	120866	120919			
6,0	4,9	DIN	120821	120815	120902	120872	120918	161025		
6,3	5,0	ISO		120885	120849	120873	120913	161026		
7,0	5,5	DIN, JIS		120886	120859	120898	120875	161027		
7,1	5,6	ISO		120857	120828	120880	120876	161028		
8,0	6,2/6,3	DIN, ISO		120887	120850	120910	120867	161029		
9,0	7,0/7,1	DIN, ISO		120888	120871	120916	120892	161030		
10,0	8,0	DIN, ISO			120829	120831	120893	161031		
11,0	9,0	DIN			120909	120832	120868	161032		
11,2	9,0	ISO			120889	120904	120882	161033		
12,0	9,0	DIN			176418	120833	120877	161034		
12,5	10,0	ISO, JIS				120905	120900	178573		
14,0	11,0/11,2	DIN, ISO, JIS				120881	120901	161035		
16,0	12,0/12,5	DIN, ISO				120890	120894	169450		
18,0	14,0/14,5	DIN, ISO					120895	173480		
20,0	16,0	DIN, ISO					120906	161036		
22,0	18,0	DIN						161037	161038	
25,0	20,0	DIN							161039	
28,0	22,0	DIN							161040	
32,0	24,0	DIN							161041	

Gewindebohrzangen Typ ET mit Längenausgleich

Threading Collets Type ET with Length Compensation

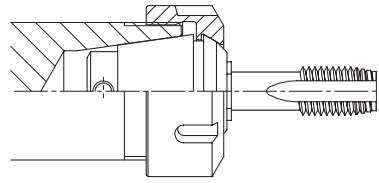

D mm	Norm Standard	Bestell-Nr. / Order No.					
		ER 11	ER 16	ER 20	ER 25	ER 32	ER 40
1,4	DIN	120801	120724*				
1,6	DIN	120735	120786*				
1,8	DIN	120825	120818*				
2,0	ISO	161000	120802				
2,2	DIN	120817	120776*	120788			
2,24	ISO	161001	120834	161006			
2,5	DIN,ISO	120785	120747*	120726	120851		
2,8	DIN, ISO	120775	120797*	120778	120837*		
3,0	JIS		120725		120780		
3,15	ISO	161002	120787	161007	120811		
3,5	DIN	120723	120771*	120803	120804*		
3,55	ISO	161003	120748	161008	120844		
4,0	DIN, ISO, JIS		120810*	120779	120826*		
4,5	DIN, ISO		120798*	120789	120838*	120839*	
5,0	ISO, JIS		120835	161009	120805	161013	
5,5	DIN, ISO		120777	161010	120860	161014	
5,6	ISO		161004	161011	120869	161015	
6,0	DIN, JIS		120843	120836	120749*	120846*	120814*
6,2	JIS				120852		
6,3	ISO		161005	161012	120870	161016	161019
7,0	DIN, JIS			120819	120812*	120863*	120848*
7,1	ISO				120861	161017	161020
8,0	DIN, ISO, JIS				120853*	120864*	120752*
8,5	JIS				120845		
9,0	DIN, ISO				120750*	120865*	120856*
10,0	DIN, ISO				120820	120854*	120751*
11,0	DIN					120862*	120855*
11,2	ISO					161018	161021
12,0	DIN					120813*	120806*
12,5	ISO, JIS					166987	161022
14,0	JIS						120840*
16,0	DIN, ISO						120841*
Satz* / Set*			152717		152718	120847	120827

* Spannzangensätze beinhalten die mit Stern* gekennzeichneten Spannzangen

* Collet sets include the star* marked collets

Gewindebohrer-Schaftmaße

Tap Shank Dimensions

Gewinde Thread		ISO 529		ISO 2283		DIN 371		DIN 357/376		DIN 352		JIS B 4430 1998		ASME B 94.9 1999	
mm	Zoll Inch	∅ mm	□ mm	∅ mm	□ mm	∅ mm	□ mm	∅ mm	□ mm	∅ mm	□ mm	∅ mm	□ mm	∅ mm	□ mm
M 1,0		2,50	2,00			2,50	2,10			2,50	2,10	3,00	2,50		
M 1,1		2,50	2,00			2,50	2,10			2,50	2,10	3,00	2,50		
M 1,2		2,50	2,00			2,50	2,10			2,50	2,10	3,00	2,50		
M 1,4		2,50	2,00			2,50	2,10			2,50	2,10	3,00	2,50		
M 1,6	1/16	2,50	2,00			2,50	2,10			2,50	2,10	3,00	2,50	0,141	0,110
M 1,7						2,50	2,10			2,50	2,10	3,00	2,50		
M 1,8		2,50	2,00			2,50	2,10			2,50	2,10	3,00	2,50	0,141	0,110
M 2,0		2,50	2,00			2,80	2,10			2,80	2,10	3,00	2,50	0,141	0,110
M 2,2		2,80	2,24			2,80	2,10			2,80	2,10	3,00	2,50	0,141	0,110
M 2,3						2,80	2,10			2,80	2,10	3,00	2,50		
M 2,5	3/32	2,80	2,24			2,80	2,10			2,80	2,10	3,00	2,50	0,141	0,110
M 2,6						2,80	2,10			2,80	2,10	3,00	2,50		
M 3,0	1/8	3,15	2,50	2,24	1,80	3,50	2,70	2,20		3,50	2,70	4,00	3,20	0,141	0,110
M 3,5		3,55	2,80	2,50	2,00	4,00	3,00	2,50	2,10	4,00	3,00	4,00	3,20	0,141	0,110
M 4,0	5/32	4,00	3,15	3,15	2,50	4,50	3,40	2,80	2,10	4,50	3,40	5,00	4,00	0,168	0,131
M 4,5	3/16	4,50	3,55	3,55	2,80	6,00	4,90	3,50	2,70	6,00	4,90	5,00	4,00	0,194	0,152
M 5,0		5,00	4,00	4,00	3,15	6,00	4,90	3,50	2,70	6,00	4,90	5,50	4,50	0,194	0,152
M 6,0	1/4	6,30	5,00	4,50	3,55	6,00	4,90	4,50	3,40	6,00	4,90	6,00	4,50	0,255	0,191
M 7,0	5/16	7,10	5,60	5,60	4,50	7,00	5,50	5,50	4,30	6,00	4,90	6,20	5,00	0,318	0,238
M 8,0		8,00	6,30	6,30	5,00	8,00	6,20	6,00	4,90	6,00	4,90	6,20	5,00	0,318	0,238
M 9,0		9,00	7,10	7,10	5,60	9,00	7,00	7,00	5,50	7,00	5,50	7,00	5,50		
M 10,0	3/8	10,00	8,00	8,00	6,30	10,00	8,00	7,00	5,50	7,00	5,50	7,00	5,50	0,387	0,286
M 11,0		8,00	6,30	8,00	6,30			8,00	6,20	8,00	6,20	8,00	6,00		
M 12,0	1/2	9,00	7,10	9,00	7,10			9,00	7,00	9,00	7,00	8,50	6,50	0,367	0,275
M 14,0	9/16	11,20	9,00	11,20	9,00			11,00	9,00	11,00	9,00	10,50	8,00	0,429	0,322
M 16,0	5/8	12,50	10,00	12,50	10,00			12,00	9,00	12,00	9,00	12,50	10,00	0,480	0,360
M 18,0	11/16	14,00	11,20	14,00	11,20			14,00	11,00	14,00	11,00	14,00	11,00	0,542	0,406
M 20,0	15/16	14,00	11,20	14,00	11,20			16,00	12,00	16,00	12,00	15,00	12,00	0,652	0,489
M 22,0	7/8	16,00	12,50	16,00	12,50			18,00	14,50	18,00	14,50	17,00	13,00	0,697	0,523
M 24,0	15/16	18,00	14,00	18,00	14,00			18,00	14,50	18,00	14,50	19,00	15,00	0,760	0,570
M 27,0	11/16	20,00	16,00					20,00	16,00	20,00	16,00	20,00	15,00	0,896	0,672
M 30,0	13/16	20,00	16,00					22,00	18,00	22,00	18,00	23,00	17,00	1,021	0,766

mimatic® Home of Innovations

- Zirkular- und Gewindefräswerkzeuge
- RPK-Reibahlen mit polygonaler Schnittstelle
- Stech- und Drehwerkzeuge
- Angetriebene Werkzeuge für CNC-Bearbeitungszentren
- Angetriebene Werkzeuge für CNC-Drehmaschinen
- Mehrspindel-Technologie
- Modulare Werkzeugaufnahmen mimatic® mi
- Statische Werkzeugaufnahmen für CNC-Drehmaschinen
- Präzisions-Spannfutter
- Sonder-Zerspannungswerkzeuge

- *Circular- and Thread Milling Tools*
- *Cutting and Turning Tools*
- *RPK-Reamers with Polygonal Interface*
- *Driven Toolholders for CNC Machining Centers*
- *Driven Toolholders for CNC Lathes*
- *Multi-spindle Technology*
- *Modular Quick Change Toolholders mimatic® mi*
- *Static Toolholders for CNC Lathes*
- *Precision Chucks*
- *Special Cutting Tools*

191722 WM-KATALOG-WK-DE-EN_01



mimatic®
Tool Systems

mimatic GmbH
Westendstraße 3
D-87488 Betzigau
Tel. +49 831-57444-0
Fax +49 831-57444-90
info@mimatic.de
www.mimatic.de